

# HANGERMate<sup>®</sup>

## Threaded Rod Anchoring System

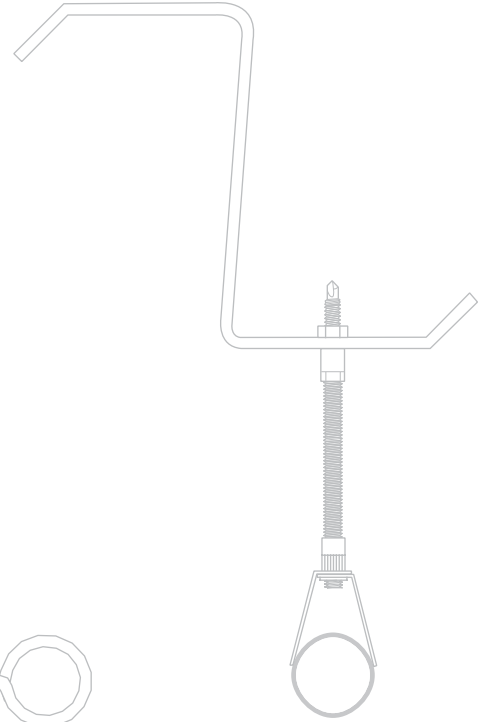

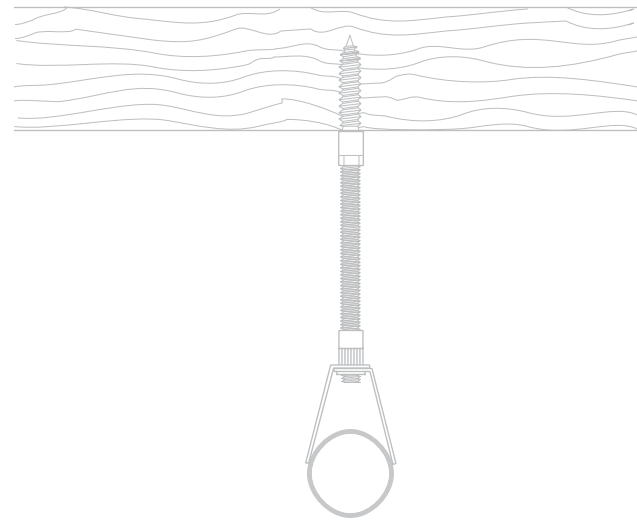
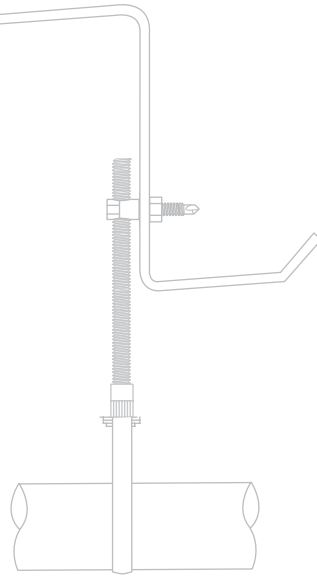
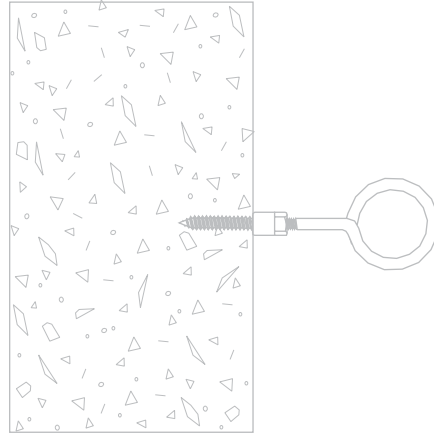
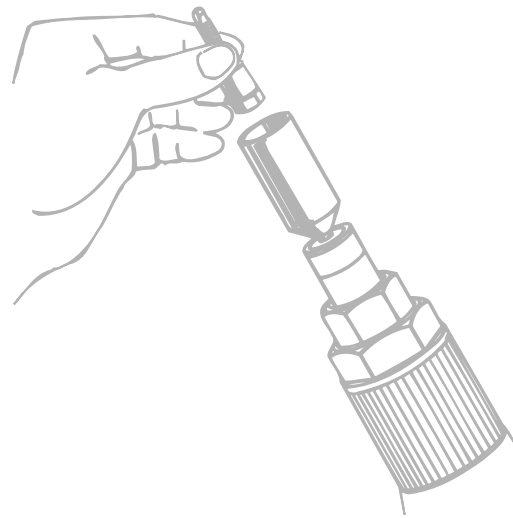

# HANGERMate®

Threaded Rod Anchoring System

HangerMate® anchors were designed to speed installation of fire sprinkler, HVAC, refrigeration, general piping, and electrical systems. They can also be used to install strut channels, cable trays, suspended ceiling grids, bridle rings and eye-rods.

HangerMate anchors can replace beam clamps, powder-actuated stud pins, eye sockets, or ceiling flanges, and eliminate labor-intensive operations such as pre-punching or drilling of steel components.

## Power of One

The entire system has been re-engineered so only one driver is needed for all anchor sizes (except HangerMate LG anchors), regardless of the substrate material. Preparing concrete applications is accomplished with a standard 1/4" drill bit.

## Head Styles

Two head styles are available:

- HangerMate vertical-mount anchors feature a tapped head to permit in-line mounting of threaded rod systems
- HangerMate side-mount anchors feature a cross-drilled and tapped head to permit side-mounting of threaded rod systems

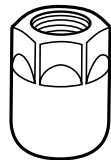

end-drilled head



cross-drilled head

Both head styles feature a wide array of thread and point styles for use in steel, concrete, masonry or wood applications, including the MP style that can be used in all three materials. Many styles are Factory Mutual (FM) approved or Underwriters Lab (UL) listed (see following pages).

Find out just how versatile and beneficial the HangerMate anchoring system can be.

## Features & Benefits

- Solid, one-piece, cold formed and machined anchor
- Entire system requires only one driver (except for HangerMate LG anchors)
- Heads precision drilled and tapped to accept 3/8-16 or 1/4-20 threaded components
- EZE270 adapter allows installation of 1/2-13 threaded rod components
- LG style allows installation of threaded rod systems into light-gage metals
- MP style can be used in metal, wood or concrete, reducing the number of parts that need to be stocked
- Different thread and point styles available to meet the requirements of specific application materials
- Special hex nuts supplied as required
- Many styles UL listed and/or FM approved (see table inside)
- Ease assembly of HVAC, fire sprinkler, refrigeration, piping, and electrical systems for ceiling- or wall-mounted applications.

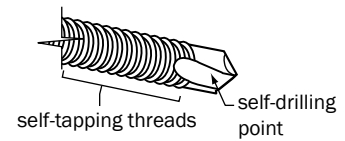

for steel applications

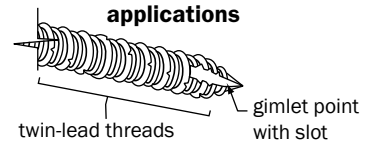

for wood applications

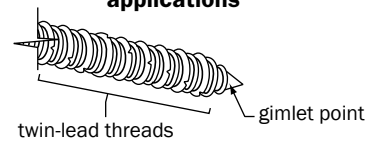

for concrete applications

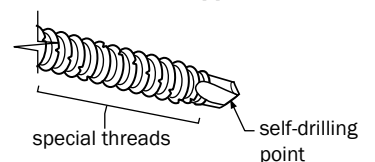

MP style for steel, wood or concrete applications



**Elco Construction Products**

1301 Kerr Drive • Decorah, IA 52101

**1.800.435.7213** • fax: 563.387.3540

[www.elcoconstruction.com](http://www.elcoconstruction.com)

## HangerMate® Threaded Rod Anchoring System

### Steel Applications\*

#### Vertical Mount – End-Drilled Head

	Rod Size	Steel Thickness	Elco Cat. No.	Description	UL Pipe Size	UL Steel Thickness	FM Pipe Size	FM Steel Thickness
	1/4-20	.060 - .250	EZG160	1/4-20X1 #3 point	N/A	N/A	N/A	N/A
	3/8-16	.060 - .125	EZG450	1/4-20X1 #2 point	4"	0.125"		
	3/8-16	.060 - .250	EZG470	1/4-20X1 #3 point	4"	0.125"	4"	12 ga.
	3/8-16	.060 - .250	EZG471	1/4-20X1 #3 point w/nuts	4"	0.060"	4"	16 ga.
	3/8-16	.060 - .250	EZG490	1/4-20X1-1/2 #3 point	4"	0.125"	4"	12 ga.
	3/8-16	.060 - .250	EZG491	1/4-20X1-1/2 #3 point w/nuts	4"	0.060"	4"	16 ga.
	3/8-16	.060 - .250	EZG530	1/4-20X2 #3 point			4"	0.125"
	3/8-16	.060 - .250	EZG540	1/4-20X3 #3 point				
	3/8-16	.187 - .500	EZG510	1/4-20X1-1/2 #5 point	4"	0.125"	4"	0.125"
	3/8-16	.060 - .500	EZG511	1/4-20X1-1/2 #5 point w/nuts	4"	0.060"	4"	16 ga.
	1/4-20	26 ga. -.187"	EZG610	1/4-20 collapsing insert	N/A	N/A	N/A	N/A
	3/8-16	26 ga. -.187"	EZG580	1/4-20X1; use with EZG610	2.5"	22 ga.	4"	12 ga.
	3/8-16	26 ga. -.187"	EZG590	1/4-20X1; use with EZG610	3.5"	18 ga.	4"	12 ga.
	3/8-16	26 ga. -.187"	EZG600	1/4-20X1; use with EZG610	4"	16 ga.	4"	12 ga.

#### Horizontal Mount – Cross-Drilled Head

	Rod Size	Steel Thickness	Elco Cat. No.	Description	UL Pipe Size	UL Steel Thickness	FM Pipe Size	FM Steel Thickness
	1/4-20	.060 - .250	EZH155	1/4-20X1 #3 point	N/A	N/A	N/A	N/A
	3/8-16	.060 - .125	EZH455	1/4-20X1 #2 point				
	3/8-16	.060 - .250	EZH475	1/4-20X1 #3 point				
	3/8-16	.060 - .250	EZH476	1/4-20X1 #3 point w/nuts	4"	0.060"	4"	16 ga.
	3/8-16	.060 - .250	EZH495	1/4-20X1-1/2 #3 point				
	3/8-16	.060 - .250	EZH496	1/4-20X1-1/2 #3 point w/nuts	4"	0.060"	4"	16 ga.
	3/8-16	.187 - .500	EZH515	1/4-20X1-1/2 #5 point				
	3/8-16	.060 - .500	EZH516	1/4-20X1-1/2 #5 point w/nuts	4"	0.060"	4"	16 ga.
	3/8-16	.060 - .250	EZH535	1/4-20X2 #3 point				

**NOTE:** It is the responsibility of the installer to determine the application-specific details under which a code approval or listing was granted. Contact Elco Construction Products for more information.

**\*Installation in Steel or Wood Applications:**



Use EZE215 drive socket (see next page). Hex drive will automatically disengage when anchor is seated.

†Collapsing insert EZG610 can be used alone to install 1/4-20 threaded components or with EZG580, EZG590 or EZG600 hangers to install 3/8-16 threaded components.

## HangerMate® Threaded Rod Anchoring System

### Wood Applications\*

#### Vertical Mount – End-Drilled Head

	Rod Size	Elco Cat. No.	Description	UL Pipe Size	FM Pipe Size
	1/4-20	EZG315	5/16X2-1/4	NA	NA
	3/8-16	EZG650	5/16X2-1/4	4"	4"
	3/8-16	EZG670	5/16X3	4"	4"

#### Horizontal Mount – Cross-Drilled Head

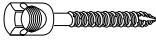
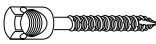
	Rod Size	Elco Cat. No.	Description	UL Pipe Size	FM Pipe Size
	1/4-20	EZH320	5/16X2-1/4	NA	NA
	3/8-16	EZH665	5/16X2-1/4	3-1/2"	

### Concrete Applications\*\*

#### Vertical Mount – End-Drilled Head

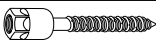
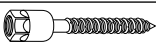

	Rod Size	Elco Cat. No.	Description	UL Pipe Size	FM Pipe Size
	1/4-20	EZG365	5/16X2-1/4	NA	NA
	3/8-16	EZG730	5/16X2-1/4		4"

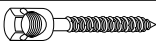
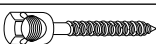
#### Horizontal Mount – Cross-Drilled Head

	Rod Size	Elco Cat. No.	Description	UL Pipe Size	FM Pipe Size
	1/4-20	EZH370	5/16X2-1/4	NA	NA
	3/8-16	EZH735	5/16X2-1/4		4"

### Steel, Wood or Concrete

#### Vertical Mount – End-Drilled Head

	Rod Size	Elco Cat. No.	Description	UL Pipe Size	FM Pipe Size
	1/4-20	EZG910	1/4-10X2	NA	NA
	3/8-16	EZG930	1/4-10X2		

#### Horizontal Mount – Cross-Drilled Head





	Rod Size	Elco Cat. No.	Description	UL Pipe Size	FM Pipe Size
	3/8-16	EZH935	1/4-10X2	NA	NA



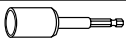
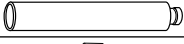

### All Materials – Adapter for Hanging 1/2" Rod†

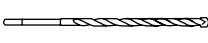
	Rod Size	Elco Cat. No.	Description	UL Pipe Size	FM Pipe Size
	1/2-13	EZE270		NA	NA

† Simply install any 3/8" HangerMate anchor as required, then thread EZE270 adapter into it. Use of adapter does not increase performance value of 3/8" HangerMate anchor. Check corresponding 3/8" anchor spec sheet for load-carrying capacity and add appropriate safety factor.

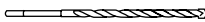
### Installation Tools

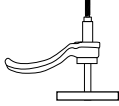
	Elco Cat. No.	Description
	EZE215	Drive Socket
	EZE220	Drive Sleeve
	EZE240	Drill Bit Adapter
	EZE320	25/64 Drill Bit with Stop Collar
	EZE340	ANSI 1/4" Tanged Drill Bit for Hammer Drills
	EZE350	ANSI 1/4" SDS Drill Bit for Rotary Hammer Drills

	Elco Cat. No.	Description
	EZE360	7/32" Tanged Drill Bit for Hammer Drills
	EZE380	7/32" SDS Drill Bit for Rotary Hammer Drills
	EZE290	Tool for EZG580/EZG590/EZG600/EZG610 components
	ELY100	Drill Bit Adapter for 7/32" drill bit

**NOTE:** It is the responsibility of the installer to determine the application-specific details under which a code approval or listing was granted. Contact Elco Construction Products for more information.

#### \*\* Installation into Concrete/Masonry Applications

Insert tanged bit (EZE340) in bit holder (EZE240), or use SDS bit (EZE350). Drill hole, then slide concrete drive socket (EZE220) over bit and onto hex. Insert anchor into socket and install. Parts can also be installed in concrete using standard 1/4" masonry bit to drill hole and use EZE215 drive socket to set anchor.

## Steel Applications

### Average Ultimate Value (lbs)\*

Cat. No.	Rod Size	Anchor Shank	Steel Thickness				
			.062"	.074"	.104"	.125"	.1875"

### End-Drilled Anchors

EZG160	1/4-20	1/4-20	786	1139	1738	2376	4694	5994
EZG450	3/8-16	1/4-20	922	1351	2273	2488	N/A	N/A
EZG470	3/8-16	1/4-20	786	1139	1738	2376	4694	5994
EZG471	3/8-16	1/4-20	3435	4024	4279	4692	5812	5909
EZG490	3/8-16	1/4-20	786	1139	1738	2376	4694	5994
EZG491	3/8-16	1/4-20	3435	4024	4279	4692	5812	5909
EZG510	3/8-16	1/4-20	N/A	N/A	N/A	N/A	3677	5207
EZG511	3/8-16	1/4-20	3435	4024	4279	4692	5812	5909
EZG530	3/8-16	1/4-20	786	1139	1738	2376	4694	5994
EZG540	3/8-16	1/4-20	786	1139	1738	2376	4694	5994

Cat. No.	Rod Size	Anchor Shank	Steel Thickness				
			.062"	.074"	.104"	.111"	.189"

### Cross-Drilled Anchors

EZH155	1/4-20	1/4-20	1739	1944	2420	2570	2809	2809
EZH455	3/8-16	1/4-20	1860	2071	2516	2606		N/A
EZH475	3/8-16	1/4-20	1739	1944	2420	2570	2809	2809
EZH476	3/8-16	1/4-20	2756	2753	2809	2809	2809	2809
EZH495	3/8-16	1/4-20	1739	1944	2420	2570	2809	2809
EZH496	3/8-16	1/4-20	2756	2753	2809	2809	2809	2809
EZH515	3/8-16	1/4-20	N/A	N/A	N/A	N/A	3529	3529
EZH516	3/8-16	1/4-20	2756	2753	2809	2809	2809	2809
EZH535	3/8-16	1/4-20	2756	2753	2809	2809	2809	2809

## Product and Warranty Information

- Code listings and approvals require that HangerMate anchors be installed with HangerMate drive sockets.
- Shoulders of installed HangerMate anchors must be flush to the metal, masonry or wood substrate materials. HangerMate anchors should not be subjected to vibratory or shock loads resulting from such applications as anchorings for reciprocating machinery, crane rails or hoists.
- Care should be taken to not damage HangerMate anchors or the substrate into which they are installed when loading pipe, installing cable tray, or otherwise suspending components from HangerMate anchors. Failure to do so may result in significant loss of holding power.
- As with all cutting tools and fasteners, normal safety precautions should be observed to avoid electrical installations, other utilities and reinforcement bars; careful use will provide the utmost safety and reliability.
- The wearing of safety glasses by users and persons in the vicinity is required by Federal Law.

This literature was prepared as an introductory summary of the HangerMate threaded rod anchoring system from Elco Construction Products and is not, therefore, intended to describe all hazards, limitations, warnings, precautions, etc. pertaining to the use of the product. The information and data presented herein are believed to be accurate and reliable, however, due to the wide variety of possible intervening factors, the suitability of the product for the use intended is the sole responsibility of the user. Specifications and other information contained herein supersede all previously published material and are subject to change without notice.

All HangerMate anchors are warranted to be manufactured free from defects in material and workmanship. Under this warranty, Elco Construction Products will provide, at no charge, replacement product for any HangerMate anchors proven to be defective when installed in accordance with our published recommendations and in applications considered by us as suitable for this product. This warranty is in lieu of any and all warranties, expressed or implied, and in no case will Elco Construction Products be liable for incidental, liquidated or consequential damages.

## Light-gage Steel Applications

Cat #	EZG580	EZG590	EZG600
Max. Pipe Diameter	2.5"	3.5"	4"
Min. Steel Thickness	22 ga.	18 ga	16 ga

### Ultimate Tensile Load\*

Gage	26	22	20	18	16
Ultimate Tensile Load	848	1025	1153	1410	1880

## Wood Applications

### Average Ultimate Value (lbs)\*

Cat#	Rod Size	Anchor Shank	Douglas Fir	Southern Pine	Hemfir
------	----------	--------------	-------------	---------------	--------

### End-Drilled Anchors

EZG315	1/4-20	5/16-14	2487	2162	1768
EZG650	3/8-16	5/16-14	2487	2162	1768
EZG670	3/8-16	5/16-14	2487	2162	1768

### Cross-Drilled Anchors

EZH320	1/4-20	5/16-14	1801	1460	1451
EZH665	3/8-16	5/16-14	1801	1460	1451

## Concrete Applications

### Average Ultimate Value (lbs)\*

Cat#	Rod Size	Anchor Shank	3650 PSI Concrete
------	----------	--------------	-------------------

### End-Drilled Anchors

EZG365	1/4-20	5/16-14	2188
EZG730	3/8-16	5/16-14	2188

### Cross-Drilled Anchors

EZH370	1/4-20	5/16-14	2767
EZH735	3/8-16	5/16-14	2767

## HangerMate MP Anchors – End-drilled Product Only

### Average Ultimate Value (lbs)

Application Material	Performance Values: End-drilled Product Only
Southern Pine	1541
16 ga. steel	880
14 ga. steel	1106
12 ga. steel	1754
1/8" steel	2505
Concrete (3300 psi)	2933

### \* Performance Testing Notes:

- The loads indicated are average ultimate values achieved under laboratory conditions and appropriate safety factors should be applied for design purposes.
- NFPA (National Fire Protection Assoc.) minimum fastening requirements are five times the weight of a 15 foot section of water filled pipe plus 250 lbs. This is 1475 lbs. for 4" pipe.
- All test values were obtained using 3/8-16 rod. When 1/4-20 rod is used, the strength of the rod may be less than the pull-out values of the anchors.
- Loads were determined by testing products in the orientation for which they were designed to be used. End-drilled parts were pulled in line with the anchor's axis while cross-drilled parts were tested with the force perpendicular to the axis.



**Elco Construction Products**

1.800.435.7213 • fax: 563.387.3540

[www.elcoconstruction.com](http://www.elcoconstruction.com)



HangerMate®, iForm™ and Infatech™ are registered trademarks of Infatech Intellectual Properties Pte Ltd. Avdel® is a registered trademark of Avdel UK Ltd. ©2011 Infatech Intellectual Properties Pte Ltd. All rights reserved.

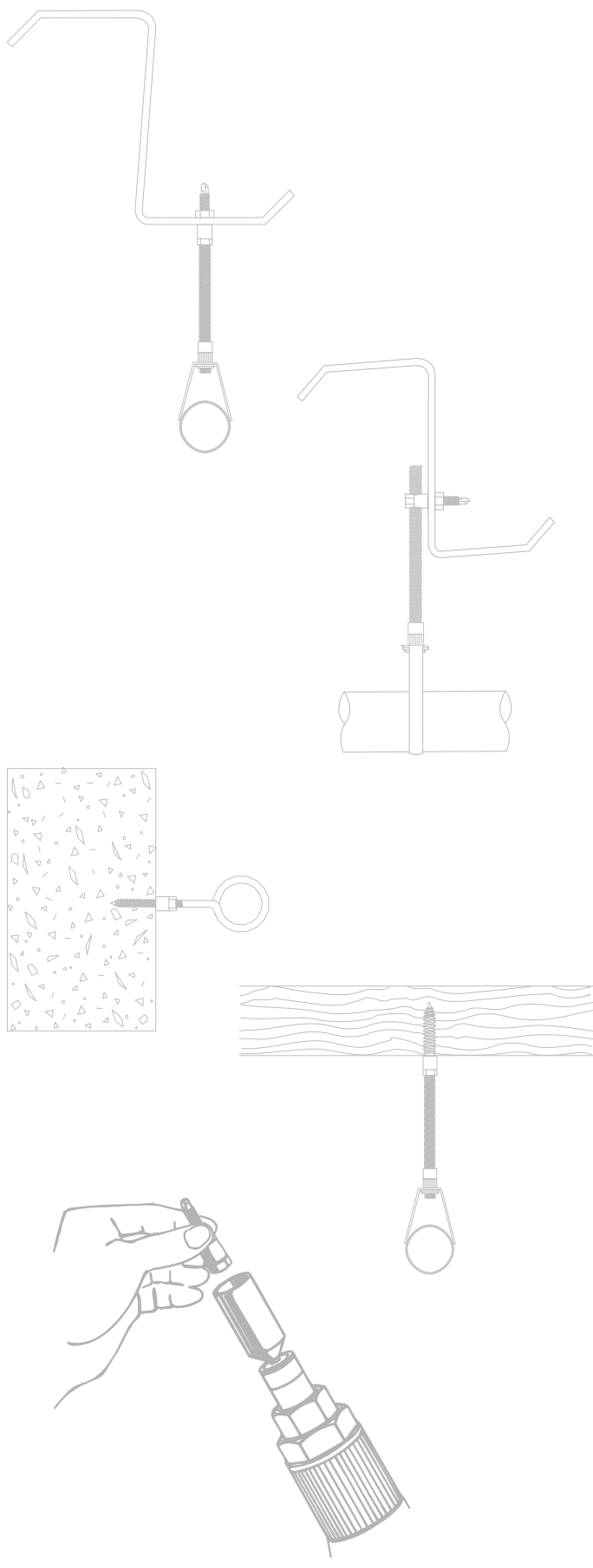

## Specifications & Applications

### Application Examples ..... 8

Note: All anchors for use with 3/8-16 rod unless otherwise noted.

### Steel Applications

#### Vertical Mount – End-Drilled Head

EZG160 .....	9
EZG450.....	10
EZG470/EZG471.....	11
EZG490/EZG491.....	12
EZG510/EZG511.....	13
EZG530/EZG540 .....	14
EZG580/EZG590/EZG600/EZG610 .....	15

#### Horizontal Mount – Cross-Drilled Head

EZH155.....	16
EZH455.....	17
EZH475/EZH476.....	18
EZH495/EZH496.....	19
EZH515/EZH516.....	20
EZH535.....	21

### Wood Applications

#### Vertical Mount – End-Drilled Head

EZG315.....	22
EZG650 /EZG670.....	23

#### Horizontal Mount – Cross-Drilled Head

EZH320 .....	24
EZH665.....	25

### Concrete Applications

#### Vertical Mount – End-Drilled Head

EZG365 .....	26
EZG730.....	27

#### Horizontal Mount – Cross-Drilled Head

EZH370 .....	28
EZH735.....	29

### Steel, Concrete or Wood Applications

#### Hangermate MP Anchors (Multi-purpose)

EZG910/EZG930/EZH935.....	30
---------------------------	----

#### HangerMate Adapter for 1/2-13 Threaded Rod

EZE270 .....	31
--------------	----

Installation Tools and Instructions.....	32
--	----

# Typical Applications

## Vertical-mount/In-line Applications

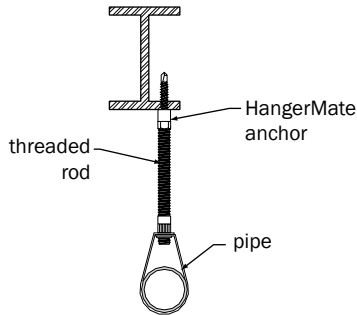

**Piping System to Bar Joist**

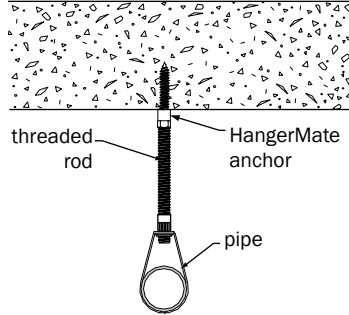

**Piping System to Concrete**

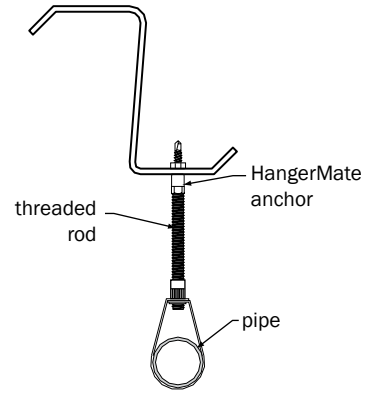

**Piping System to Z-purlin**

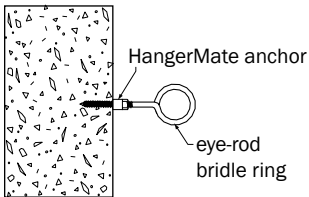

**Eye-Rod for Cable/Coaxial/Electrical to Concrete**

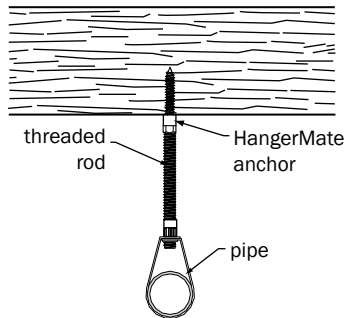

**Piping System to Wood**

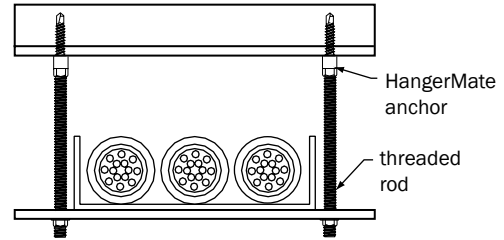

**Cable Tray to Steel Channel**

## Side-mount Applications

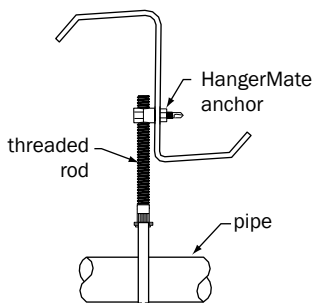

**Piping System to Z-purlin**

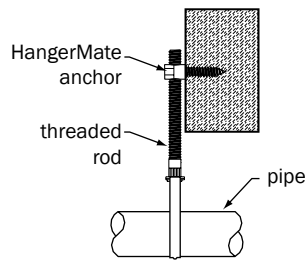

**Piping System to Concrete or Wood**

HangerMate anchors were designed to speed installation of:

- fire sprinkler
- HVAC
- refrigeration
- general piping
- electrical/lighting systems
- strut channels
- cable trays
- suspended ceiling grids
- bridle rings
- eye rods



## Elco Construction Products

1301 Kerr Drive • Decorah, IA 52101

**1.800.435.7213** • fax: 563.387.3540

[www.elcoconstruction.com](http://www.elcoconstruction.com)





# SPECIFICATIONS

## HangerMate® Threaded Rod Anchoring System EZG160 Anchors

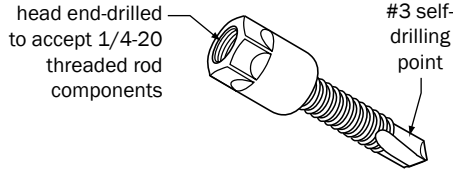

### Features & Benefits

- End-drilled and tapped for attaching 1/4-20 threaded components to steel
- Solid, one piece cold formed part; head cannot spin off or unscrew from body
- #3 self-drilling point for steel thicknesses of .060 - .250"

### Performance Values for EZG160 Anchor

Steel Thickness	Average Ultimate Value (lbs)
0.062"	786
0.074"	1139
0.104"	1738
0.125"	2376
0.1875"	4694
0.250"	5994

1. The loads indicated above are average ultimate values achieved under laboratory conditions and appropriate safety factors should be applied for design purposes.
2. NFPA (National Fire Protection Assoc.) minimum fastening requirements are five times the weight of a 15 ft section of water-filled pipe plus 250 lbs. This is 1475 lbs. for 4" pipe.
3. All test values were obtained using 3/8-16 rod. When 1/4-20 rod is used, the strength of the rod may be less than the pull-out values of the anchors.
4. Loads were determined by testing products in the orientation for which they were designed to be used. End-drilled parts were pulled in line with the anchor's axis while cross-drilled parts were tested with the force perpendicular to the axis.

### EZG160 HangerMate Anchors

#### Application Material:

Steel .060" - .250"

#### Specification:

1/4" shank diameter, one-piece anchor with end-drilled head to accept 1/4-20 threaded rod and components, #3 self-drilling point and self-tapping threads

#### UL Listings and FM Approvals:

None (1/4-20 rod not used for sprinkler applications)

#### Head Style:

9/16" diameter head end-drilled and tapped to accept 1/4-20 threaded components

#### Head Height:

3/4"

#### Drive Hex Size:

1/2" across flats

#### Shank Length:

1"

#### Shank Threads:

1/4-20 self-tapping

#### Point Type:

#3 self-drilling

#### Material & Heat Treat:

Carbon steel (AISI C10B21) case hardened and tempered

#### Finish:

Zinc plated per ASTM B633 Type II Class 5

#### Installation Tools:

- HangerMate drive socket: EZE215 with safety set feature; automatically disengages when anchor is seated
- Recommended power tool: Contractor-grade screw gun; 12 volt min. cordless or 4.5 amp min. corded tool 1300 - 2000 rpm

For more information, contact

**Elco Construction Products • 1.800.435.7213**

**www.elcoconstruction.com**



# S P E C I F I C A T I O N S

## HangerMate® Threaded Rod Anchoring System EZG450 Anchors

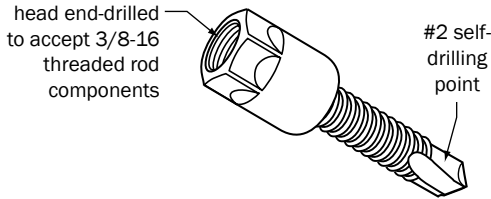

### Features & Benefits

- End-drilled and tapped for attaching 3/8-16 threaded components to steel
- Solid, one piece cold formed part; head cannot spin off or unscrew from body
- #2 self-drilling point for steel
- Provides increased pullout in thinner material thicknesses of .060" – .125"

### Performance Values for EZG450 Anchor

Steel Thickness	Average Ultimate Value (lbs)
0.062"	922
0.074"	1351
0.104"	2273
0.125"	2488
0.1875"	N/A
0.250"	N/A

1. The loads indicated above are average ultimate values achieved under laboratory conditions and appropriate safety factors should be applied for design purposes.
2. NFPA (National Fire Protection Assoc.) minimum fastening requirements are five times the weight of a 15 ft section of water-filled pipe plus 250 lbs. This is 1475 lbs. for 4" pipe.
3. Loads were determined by testing products in the orientation for which they were designed to be used. End-drilled parts were pulled in line with the anchor's axis while cross-drilled parts were tested with the force perpendicular to the axis.

### EZG450 HangerMate Anchors

#### Application Material:

Steel .060" – .125"

#### Specification:

1/4" shank diameter, one-piece anchor with end-drilled head to accept 3/8-16 threaded rod and components, #2 self-drilling point and self-tapping threads

#### UL Listings and FM Approvals:

- UL listed for 4" pipe minimum steel thickness of 0.125"

#### Head Style:

9/16" diameter head end-drilled and tapped to accept 3/8-16 threaded components

#### Head Height:

3/4"

#### Drive Hex Size:

1/2" across flats

#### Shank Length:

1"

#### Shank Threads:

1/4-20 self-tapping

#### Point Type:

#2 self-drilling

#### Material & Heat Treat:

Carbon steel (AISI C10B21) case hardened and tempered

#### Finish:

Zinc plated per ASTM B633 Type II Class 5

#### Installation Tools:

- HangerMate drive socket: EZE215 with safety set feature; automatically disengages when anchor is seated
- Recommended power tool: Contractor-grade screw gun; 12 volt min. cordless or 4.5 amp min. corded tool 1300 – 2000 rpm

For more information, contact

**Elco Construction Products • 1.800.435.7213**

**www.elcoconstruction.com**

HangerMate®, Elco® and Infastech™ are registered trademarks of Infastech Intellectual Properties Pte Ltd.



# SPECIFICATIONS

## HangerMate® Threaded Rod Anchoring System EZG470 & EZG471 Anchors

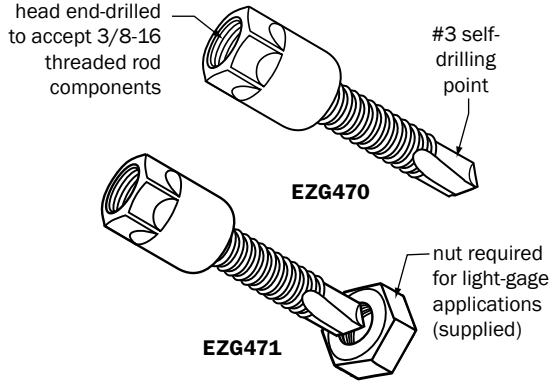

### Features & Benefits

- End-drilled and tapped for attaching 3/8-16 threaded components to steel
- Solid, one piece cold formed part; head cannot spin off or unscrew from body
- #3 self-drilling point for steel thicknesses of .060 - .250"
- EZG471 includes backing nuts which greatly improves pullout values in thin material and are required to meet certain UL/FM requirements

### Performance Values for EZG470 Anchor (no nut)

Steel Thickness	Average Ultimate Value (lbs)
0.062"	786
0.074"	1139
0.104"	1738
0.125"	2376
0.1875"	4694
0.250"	5994

### Performance Values for EZG471 Anchor (with nut)

Steel Thickness	Average Ultimate Value (lbs)
0.062"	3435
0.074"	4024
0.104"	4279
0.125"	4692
0.1875"	5812
0.250"	5909

1. The loads indicated above are average ultimate values achieved under laboratory conditions and appropriate safety factors should be applied for design purposes.
2. NFPA (National Fire Protection Assoc.) minimum fastening requirements are five times the weight of a 15 ft section of water-filled pipe plus 250 lbs. This is 1475 lbs. for 4" pipe.
3. Loads were determined by testing products in the orientation for which they were designed to be used. End-drilled parts were pulled in line with the anchor's axis while cross-drilled parts were tested with the force perpendicular to the axis.

### EZG470 & EZG471 HangerMate Anchors

#### Application Material:

Steel .060" - .250"

#### Specification:

1/4" shank diameter, one-piece anchor with end-drilled head to accept 3/8-16 threaded rod and components, #3 self-drilling point and self-tapping threads

#### UL Listings and FM Approvals:

- EZG470 is UL listed for 4" pipe in a minimum steel thickness of 0.125" and FM approved for 4" pipe in a minimum steel thickness of 12 gage (0.10")
- EZG471 (with nuts) is UL listed and FM approved for 4" pipe in 16 gage steel (0.060")

#### Head Style:

9/16" diameter head end-drilled and tapped to accept 3/8-16 threaded components

#### Head Height:

3/4"

#### Drive Hex Size:

1/2" across flats

#### Shank Length:

1"

#### Shank Threads:

1/4-20 self-tapping

#### Point Type:

#3 self-drilling

#### Material & Heat Treat:

Carbon steel (AISI C10B21) case hardened and tempered

#### Finish:

Zinc plated per ASTM B633 Type II Class 12

#### Installation Tools:

- HangerMate drive socket: EZE215 with safety set feature; automatically disengages when anchor is seated
- Recommended power tool: Contractor-grade screw gun; 12 volt min. cordless or 4.5 amp min. corded tool 1300 - 2000 rpm

For more information, contact

**Elco Construction Products • 1.800.435.7213**  
**www.elcoconstruction.com**



# SPECIFICATIONS

## HangerMate® Threaded Rod Anchoring System EZG490 & EZG491 Anchors

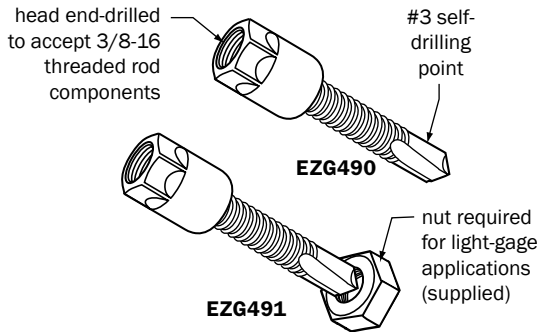

### Features & Benefits

- End-drilled and tapped for attaching 3/8-16 threaded components to steel
- Solid, one piece cold formed part; head cannot spin off or unscrew from body
- #3 self-drilling point for steel thicknesses of .060 - .250"
- EZG491 includes backing nuts which greatly improves pullout values in thin material and are required to meet certain UL/FM requirements

### Performance Values for EZG490 Anchor (no nut)

Steel Thickness	Average Ultimate Value (lbs)
0.062"	786
0.074"	1139
0.104"	1738
0.125"	2376
0.1875"	4694
0.250"	5994

### Performance Values for EZG491 Anchor (with nut)

Steel Thickness	Average Ultimate Value (lbs)
0.062"	3435
0.074"	4024
0.104"	4279
0.125"	4692
0.1875"	5812
0.250"	5909

1. The loads indicated above are average ultimate values achieved under laboratory conditions and appropriate safety factors should be applied for design purposes.
2. NFPA (National Fire Protection Assoc.) minimum fastening requirements are five times the weight of a 15 ft section of water-filled pipe plus 250 lbs. This is 1475 lbs. for 4" pipe.
3. Loads were determined by testing products in the orientation for which they were designed to be used. End-drilled parts were pulled in line with the anchor's axis while cross-drilled parts were tested with the force perpendicular to the axis.

### EZG490 & EZG491 HangerMate Anchors

#### Application Material:

Steel .060" - .250"

#### Specification:

1/4" shank diameter, one-piece anchor with end-drilled head to accept 3/8-16 threaded rod and components, #3 self-drilling point and self-tapping threads

#### UL Listings and FM Approvals:

- EZG490 is UL listed for 4" pipe minimum steel thickness of 0.125" and FM approved for 4" pipe in minimum steel thickness of 12 gage (0.10")
- EZG491 (with nuts) is UL listed and FM approved for 4" pipe in 16 gage steel (0.060")

#### Head Style:

9/16" diameter head end-drilled and tapped to accept 3/8-16 threaded components

#### Head Height:

3/4"

#### Drive Hex Size:

1/2" across flats

#### Shank Length:

1-1/2"

#### Shank Threads:

1/4-20 self-tapping

#### Point Type:

#3 self-drilling

#### Material & Heat Treat:

Carbon steel (AISI C10B21) case hardened and tempered

#### Finish:

Zinc plated per ASTM B633 Type II Class 12

#### Installation Tools:

- HangerMate drive socket: EZE215 with safety set feature; automatically disengages when anchor is seated
- Recommended power tool: Contractor-grade screw gun; 12 volt min. cordless or 4.5 amp min. corded tool 1300 - 2000 rpm

For more information, contact

**Elco Construction Products • 1.800.435.7213**  
**www.elcoconstruction.com**



# SPECIFICATIONS

## HangerMate® Threaded Rod Anchoring System EZG510 & EZG511 Anchors

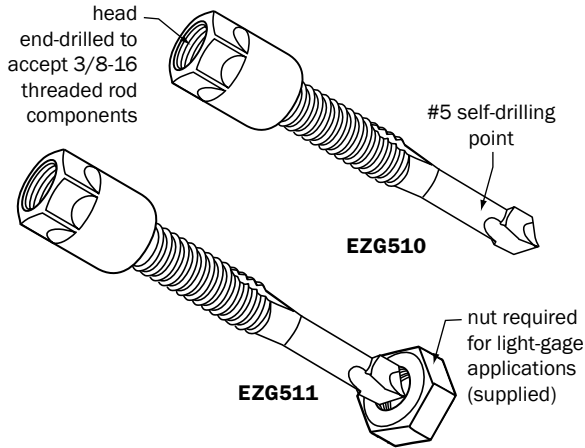

### Features & Benefits

- End-drilled and tapped for attaching 3/8-16 threaded components to steel
- Solid, one piece cold formed part; head cannot spin off or unscrew from body
- #5 self-drilling point for steel is designed for thicknesses of .187" – .500" but can be used with backing nuts in thinner applications
- EZG511 includes backing nuts which are required to meet certain UL/FM requirements

### Performance Values for EZG490 Anchor (no nut)

Steel Thickness	Average Ultimate Value (lbs)
0.062" - 0.125"	N/A
0.1875"	3677
0.250"	5207

### Performance Values for EZG491 Anchor (with nut)

Steel Thickness	Average Ultimate Value (lbs)
0.062"	3435
0.074"	4024
0.104"	4279
0.125"	4692
0.1875"	5812
0.250"	5909

1. The loads indicated above are average ultimate values achieved under laboratory conditions and appropriate safety factors should be applied for design purposes.
2. NFPA (National Fire Protection Assoc.) minimum fastening requirements are five times the weight of a 15 ft section of water-filled pipe plus 250 lbs. This is 1475 lbs. for 4" pipe.
3. Loads were determined by testing products in the orientation for which they were designed to be used. End-drilled parts were pulled in line with the anchor's axis while cross-drilled parts were tested with the force perpendicular to the axis.

### EZG510 & EZG511 HangerMate Anchors

#### Application Material:

Steel .187" – .500"

#### Specification:

1/4" shank diameter, one-piece anchor with end-drilled head to accept 3/8-16 threaded rod and components, #5 self-drilling point and self-tapping threads

#### UL Listings and FM Approvals:

- EZG510 is UL listed and FM approved for 4" pipe in minimum steel thickness of 0.125"
- EZG511 (with nuts) is UL listed and FM approved for 4" pipe in 16 gage steel (0.060")

#### Head Style:

9/16" diameter head end-drilled and tapped to accept 3/8-16 threaded components

#### Head Height:

3/4"

#### Drive Hex Size:

1/2" across flats

#### Shank Length:

1-1/2"

#### Shank Threads:

1/4-20 self-tapping

#### Point Type:

#5 self-drilling

#### Material & Heat Treat:

Carbon steel (AISI C10B21) case hardened and tempered

#### Finish:

Zinc plated per ASTM B633 Type II Class 12

#### Installation Tools:

- HangerMate drive socket: EZE215 with safety set feature; automatically disengages when anchor is seated
- Recommended power tool: Contractor-grade screw gun; 12 volt min. cordless or 4.5 amp min. corded tool 1300 – 2000 rpm

For more information, contact

**Elco Construction Products • 1.800.435.7213**

**www.elcoconstruction.com**



# S P E C I F I C A T I O N S

## HangerMate® Threaded Rod Anchoring System EZG530 & EZG540 Anchors

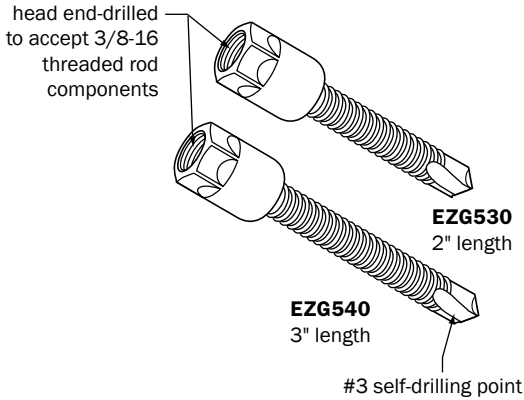

### Features & Benefits

- End-drilled and tapped for attaching 3/8-16 threaded components to steel
- Solid, one piece cold formed part; head cannot spin off or unscrew from body
- #3 self-drilling point for steel thicknesses of .060 - .250"

### Performance Values for EZG530 & EZG540 Anchors

Steel Thickness	Average Ultimate Value (lbs)
0.062"	786
0.074"	1139
0.104"	1738
0.125"	2376
0.1875"	4694
0.250"	5994

### EZG530 & EZG540 HangerMate Anchors

#### Application Material:

Steel .060" - .250"

#### Specification:

1/4" shank diameter, one-piece anchor with end-drilled head to accept 3/8-16 threaded rod and components, #3 self-drilling point and self-tapping threads

#### UL Listings and FM Approvals:

- EZG530 only is FM approved for 4" pipe in minimum steel thickness of 0.125"

#### Head Style:

9/16" diameter head end-drilled and tapped to accept 3/8-16 threaded components

#### Head Height:

3/4"

#### Drive Hex Size:

1/2" across flats

#### Shank Length:

EZG530: 2"

EZG540: 3"

#### Shank Threads:

1/4-20 self-tapping

#### Point Type:

#3 self-drilling

#### Material & Heat Treat:

Carbon steel (AISI C10B21) case hardened and tempered

#### Finish:

Zinc plated per ASTM B633 Type II Class 5

#### Installation Tools:

- HangerMate drive socket: EZE215 with safety set feature; automatically disengages when anchor is seated
- Recommended power tool: Contractor-grade screw gun; 12 volt min. cordless or 4.5 amp min. corded tool  
1300 - 2000 rpm

For more information, contact

**Elco Construction Products • 1.800.435.7213**

**www.elcoconstruction.com**

1. The loads indicated above are average ultimate values achieved under laboratory conditions and appropriate safety factors should be applied for design purposes.

2. NFPA (National Fire Protection Assoc.) minimum fastening requirements are five times the weight of a 15 ft section of water-filled pipe plus 250 lbs. This is 1475 lbs. for 4" pipe.

3. Loads were determined by testing products in the orientation for which they were designed to be used. End-drilled parts were pulled in line with the anchor's axis while cross-drilled parts were tested with the force perpendicular to the axis.





# SPECIFICATIONS

## HangerMate® LG Threaded Rod Anchoring System EZG580/EZG590/EZG600/ EZG610 Components

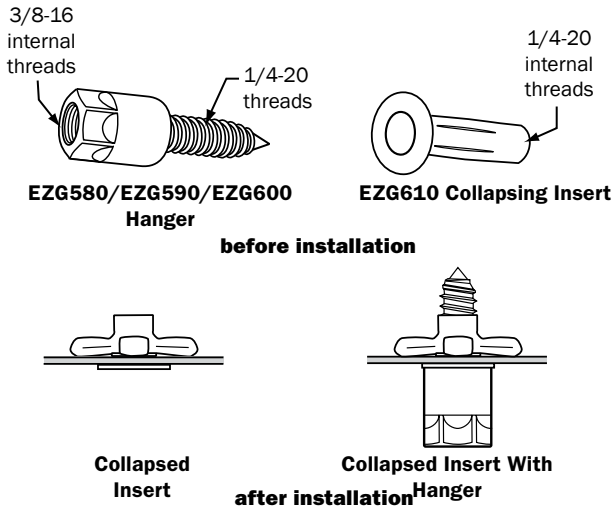

- Collapsible insert (EZG610) forms a large bearing area; can be used with or without\* hanger component
- Hangers (EZG580, EZG590 & EZG600) are traditional HangerMate one-piece design, end drilled & tapped for 3/8-16 threaded components
- Allows use in very thin materials and/or blind applications
- Installation is fast and easy

\* Insert accepts 1/4-20 threaded components and hanger; combined hanger and insert combination accepts 3/8-16 threaded components

### Performance Values for EZG580, EZG590, EZG600 Components

#### UL Listed Applications

Cat #	EZG580	EZG590	EZG600
Max. Pipe Diameter	2.5"	3.5"	4"
Min. Steel Thickness	22 ga.	18 ga	16 ga

Note: When used in UL listed applications, the EZG580, EZG590 & EZG600 must be used for the maximum pipe size and in the minimum material thickness indicated. For inspection purposes, the EZG580 & EZG590 have the maximum pipe size stamped on the side of the head. The EZG600 does not require a mark since it is listed for 4" pipe. For non-UL applications, use any of the parts based on Ultimate Tensile Load table below.

#### Ultimate Tensile Load<sup>1</sup>

Gage	26	22	20	18	16
Ultimate Tensile Load	848	1025	1153	1410	1880

1. The loads indicated above are average ultimate values achieved under laboratory conditions and appropriate safety factors should be applied for design purposes.

### EZG580/EZG590/EZG600 HangerMate Components

#### Application Material:

Steel 26 ga. – .187"; requires 25/64" pre-drilled hole

#### Specification:

Hanger: 1/4" shank diameter, one-piece anchor with end-drilled head to accept 3/8-16 threaded rod and components. Insert collapses during installation to form large bearing surface.

#### UL Listings:

EZG580: max. 2.5" pipe in min. 22 gage steel

EZG590: max. 3.5" pipe in min. 18 gage steel

EZG600: max. 4" pipe in min. 16 gage steel

Note: When used in UL listed applications, the EZG580, EZG590 & EZG600 must be used for the maximum pipe size and in the minimum material thickness indicated. For inspection purposes, the EZG580 & EZG590 have the maximum pipe size stamped on the side of the head. The EZG600 does not require a mark since it is listed for 4" pipe. For non-UL applications, use any of the parts based on Ultimate Tensile Load table to the left.

#### FM Approvals:

EZG580, EZG590 and EZG600: 4" pipe in minimum steel thickness of 0.105" (12 gage)

#### Head Style (EZG580, EZG590, EZG600):

9/16" diameter head end-drilled and tapped to accept 3/8-16 threaded components

#### Head Height (EZG580, EZG590, EZG600):

3/4"

#### Shank Length (EZG580, EZG590, EZG600):

1"

#### Collapsing Insert: (EZG610)

9/16" head, .060" thick, 1" under head

#### Material & Heat Treat:

- Hanger: Carbon steel (AISI C10B21); Grade 5.2 heat treat
- Collapsing insert: Carbon steel (AISI C1008/1010); no heat treat

#### Finish:

Hanger and collapsing insert: Zinc plated per ASTM B633 Type II Class 12

#### Installation Accessories:

Use collared 25/64" drill bit (EZE320) to pre-drill hole. Must use EZE290 tool to install collapsing insert. Hangers for 3/8-16 threaded components can then be installed by hand. **1/4-20 threaded components can be installed directly into the collapsed insert.**

For more information, contact

**Elco Construction Products • 1.800.435.7213**

**e-mail: infoelco@acument.com**



# S P E C I F I C A T I O N S

## HangerMate® Threaded Rod Anchoring System EZH155 Anchors

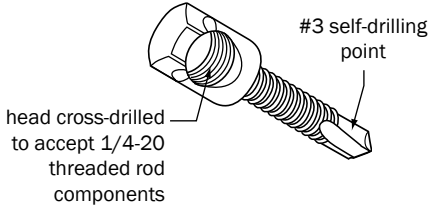

### Features & Benefits

- Cross- drilled and tapped for attaching 1/4-20 threaded components to steel
- Solid, one piece cold formed part; head cannot spin off or unscrew from body
- #3 self-drilling point for steel thicknesses of .060 – .250"

### Performance Values for EZG155 Anchor

Steel Thickness	Average Ultimate Value (lbs)
0.062"	1739
0.074"	1944
0.104"	2420
0.111"	2570
0.189"	2809
0.248"	2809

1. The loads indicated above are average ultimate values achieved under laboratory conditions and appropriate safety factors should be applied for design purposes.
2. NFPA (National Fire Protection Assoc.) minimum fastening requirements are five times the weight of a 15 ft section of water-filled pipe plus 250 lbs. This is 1475 lbs. for 4" pipe.
3. All test values were obtained using 3/8-16 rod. When 1/4-20 rod is used, the strength of the rod may be less than the pull-out values of the anchors.
4. Loads were determined by testing products in the orientation for which they were designed to be used. End-drilled parts were pulled in line with the anchor's axis while cross-drilled parts were tested with the force perpendicular to the axis.

### EZH155 HangerMate Anchors

#### Application Material:

Steel .060" – .250"

#### Specification:

1/4" shank diameter, one-piece anchor with cross-drilled head to accept 1/4-20 threaded rod and components, #3 self-drilling point and self-tapping threads

#### UL Listings and FM Approvals:

None (1/4-20 rod not used for sprinkler applications)

#### Head Style:

9/16" diameter head cross-drilled and tapped to accept 1/4-20 threaded components

#### Head Height

3/4"

#### Drive Hex Size:

1/2" across flats

#### Shank Length:

1"

#### Shank Threads:

1/4-20 self-tapping

#### Point Type:

#3 self-drilling

#### Material & Heat Treat:

Carbon steel (AISI C10B21) case hardened and tempered

#### Finish:

Zinc plated per ASTM B633 Type II Class 5

#### Installation Tools:

HangerMate drive socket: EZE215 with safety set feature; automatically disengages when anchor is seated

Recommended power tool: Contractor-grade screw gun; 12 volt min. cordless or 4.5 amp min. corded tool  
1300 – 2000 rpm

For more information, contact

**Elco Construction Products • 1.800.435.7213**

**www.elcoconstruction.com**





# HangerMate® Threaded Rod Anchoring System

## EZH455 Anchors

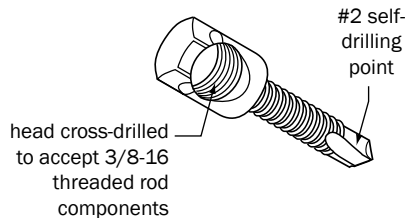

### Features & Benefits

- Cross-drilled and tapped for attaching 3/8-16 threaded components to steel
- Solid, one piece cold formed part; head cannot spin off or unscrew from body
- #2 self-drilling point for steel which provides increased pull-out in thinner material thicknesses of .060" - .125"

### Performance Values for EZG455 Anchor

Steel Thickness	Average Ultimate Value (lbs)
0.062"	1860
0.074"	2071
0.104"	2516
0.111"	2606
0.189"	N/A
0.248"	N/A

1. The loads indicated above are average ultimate values achieved under laboratory conditions and appropriate safety factors should be applied for design purposes.
2. NFPA (National Fire Protection Assoc.) minimum fastening requirements are five times the weight of a 15 ft section of water-filled pipe plus 250 lbs. This is 1475 lbs. for 4" pipe.
3. Loads were determined by testing products in the orientation for which they were designed to be used. End-drilled parts were pulled in line with the anchor's axis while cross-drilled parts were tested with the force perpendicular to the axis.

# SPECIFICATIONS

## EZH455 HangerMate Anchors

### Application Material:

Steel .060" - .125"

### Specification:

1/4" shank diameter, one-piece anchor with cross-drilled head to accept 3/8-16 threaded rod and components, #2 self-drilling point and self-tapping threads

### UL Listings and FM Approvals:

None

### Head Style:

9/16" diameter head cross-drilled and tapped to accept 3/8-16 threaded components

### Head Height

3/4"

### Drive Hex Size:

1/2" across flats

### Shank Length:

1"

### Shank Threads:

3/8-16 self-tapping

### Point Type:

#2 self-drilling

### Material & Heat Treat:

Carbon steel (AISI C10B21) case hardened and tempered

### Finish:

Zinc plated per ASTM B633 Type II Class 5

### Installation Tools:

HangerMate drive socket: EZE215 with safety set feature; automatically disengages when anchor is seated

Recommended power tool: Contractor-grade screw gun; 12 volt min. cordless or 4.5 amp min. corded tool  
1300 - 2000 rpm

For more information, contact

**Elco Construction Products • 1.800.435.7213**

**www.elcoconstruction.com**



# SPECIFICATIONS

## HangerMate® Threaded Rod Anchoring System EZH475 & EZH476 Anchors

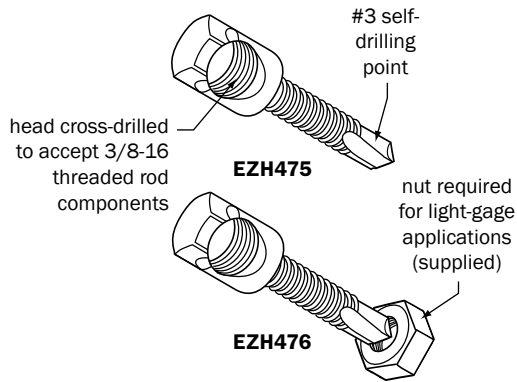

### Features & Benefits

- Cross-drilled and tapped for attaching 3/8-16 threaded components to steel
- Solid, one piece cold formed part; head cannot spin off or unscrew from body
- #3 self-drilling point for steel thicknesses of .060 – .250"
- EZH476 includes backing nuts which greatly improves pullout values in thin material and are required to meet UL requirements

### Performance Values for EZG475 Anchor (no nut)

Steel Thickness	Average Ultimate Value (lbs)
0.062"	1739
0.074"	1944
0.104"	2420
0.111"	2570
0.189"	2809
0.248"	2809

### Performance Values for EZG476 Anchor (with nut)

Steel Thickness	Average Ultimate Value (lbs)
0.062"	2756
0.074"	2753
0.104"	2809
0.111"	2809
0.189"	2809
0.248"	2809

1. The loads indicated above are average ultimate values achieved under laboratory conditions and appropriate safety factors should be applied for design purposes.
2. NFPA (National Fire Protection Assoc.) minimum fastening requirements are five times the weight of a 15 ft section of water-filled pipe plus 250 lbs. This is 1475 lbs. for 4" pipe.
3. Loads were determined by testing products in the orientation for which they were designed to be used. End-drilled parts were pulled in line with the anchor's axis while cross-drilled parts were tested with the force perpendicular to the axis.

### EZH475 & EZH476 HangerMate Anchors

#### Application Material:

Steel .060" – .250"

#### Specification:

1/4" shank diameter, one-piece anchor with cross-drilled head to accept 3/8-16 threaded rod and components, #3 self-drilling point and self-tapping threads

#### UL Listings and FM Approvals:

- EZH475: None
- EZH476 (with nuts) is UL listed and FM approved for 4" pipe in 16 gage steel (0.060")

#### Head Style:

9/16" diameter head cross-drilled and tapped to accept 3/8-16 threaded components

#### Head Height

3/4"

#### Drive Hex Size:

1/2" across flats

#### Shank Length:

1"

#### Shank Threads:

3/8-16 self-tapping

#### Point Type:

#3 self-drilling

#### Material & Heat Treat:

Carbon steel (AISI C10B21) case hardened and tempered

#### Finish:

Zinc plated per ASTM B633 Type II Class 12

#### Installation Tools:

HangerMate drive socket: EZE215 with safety set feature; automatically disengages when anchor is seated

Recommended power tool: Contractor-grade screw gun; 12 volt min. cordless or 4.5 amp min. corded tool 1300 – 2000 rpm

For more information, contact

**Elco Construction Products • 1.800.435.7213**  
**www.elcoconstruction.com**



# SPECIFICATIONS

## HangerMate® Threaded Rod Anchoring System EZH495 & EZH496 Anchors

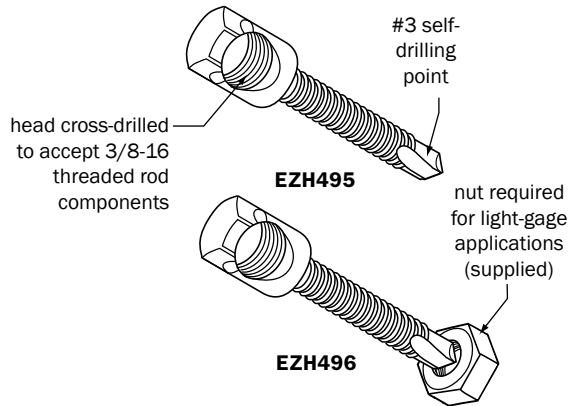

### Features & Benefits

- Cross-drilled and tapped for attaching 3/8-16 threaded components to steel
- Solid, one piece cold formed part; head cannot spin off or unscrew from body
- #3 self-drilling point for steel thicknesses of .060 - .250"
- EZH496 includes backing nuts which greatly improves pullout values in thin material and are required to meet UL requirements

### Performance Values for EZH495 Anchor (no nut)

Steel Thickness	Average Ultimate Value (lbs)
0.062"	1739
0.074"	1944
0.104"	2420
0.111"	2570
0.189"	2809
0.248"	2809

### Performance Values for EZH496 Anchor (with nut)

Steel Thickness	Average Ultimate Value (lbs)
0.062"	2756
0.074"	2753
0.104"	2809
0.111"	2809
0.189"	2809
0.248"	2809

1. The loads indicated above are average ultimate values achieved under laboratory conditions and appropriate safety factors should be applied for design purposes.
2. NFPA (National Fire Protection Assoc.) minimum fastening requirements are five times the weight of a 15 ft section of water-filled pipe plus 250 lbs. This is 1475 lbs. for 4" pipe.
3. Loads were determined by testing products in the orientation for which they were designed to be used. End-drilled parts were pulled in line with the anchor's axis while cross-drilled parts were tested with the force perpendicular to the axis.

### EZH495 & EZH496 HangerMate Anchors

#### Application Material:

Steel .060" - .250"

#### Specification:

1/4" shank diameter, one-piece anchor with end-drilled head to accept 3/8-16 threaded rod and components, #3 self-drilling point and self-tapping threads

#### UL Listings and FM Approvals:

- EZH495: None
- EZH496 (with nuts) is UL listed and FM approved for 4" pipe in 16 gage steel (0.060")

#### Head Style:

9/16" diameter head cross-drilled and tapped to accept 3/8-16 threaded components

#### Head Height

3/4"

#### Drive Hex Size:

1/2" across flats

#### Shank Length:

1-1/2"

#### Shank Threads:

3/8-16 self-tapping

#### Point Type:

#3 self-drilling

#### Material & Heat Treat:

Carbon steel (AISI C10B21) case hardened and tempered

#### Finish:

Zinc plated per ASTM B633 Type II Class 12

#### Installation Tools:

HangerMate drive socket: EZE215 with safety set feature; automatically disengages when anchor is seated

Recommended power tool: Contractor-grade screw gun; 12 volt min. cordless or 4.5 amp min. corded tool 1300 - 2000 rpm

For more information, contact

**Elco Construction Products • 1.800.435.7213**  
**www.elcoconstruction.com**



# S P E C I F I C A T I O N S

## HangerMate® Threaded Rod Anchoring System EZH515 & EZH516 Anchors

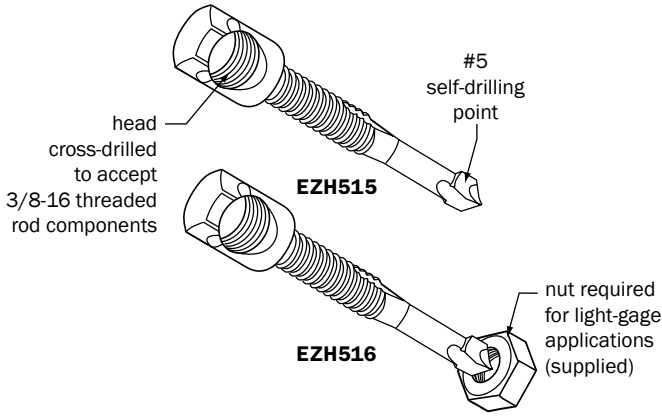

### Features & Benefits

- Cross-drilled and tapped for attaching 3/8-16 threaded components to steel
- Solid, one piece cold formed part; head cannot spin off or unscrew from body
- #5 self-drilling point for steel is designed for thicknesses of .187" – .500" but can be used with backing nuts in thinner applications
- EZH516 includes backing nuts which are required to meet UL requirements

### Performance Values for EZH515 Anchor (no nut)

Steel Thickness	Average Ultimate Pull-Out Value (lbs)
0.062" - 0.111"	N/A
0.189"	3529
0.248"	3529

### Performance Values for EZG516 Anchor (with nut)

Steel Thickness	Average Ultimate Pull-Out Value (lbs)
0.062"	2756
0.074"	2753
0.104"	2809
0.111"	2809
0.189"	2809
0.248"	2809

1. The loads indicated above are average ultimate values achieved under laboratory conditions and appropriate safety factors should be applied for design purposes.
2. NFPA (National Fire Protection Assoc.) minimum fastening requirements are five times the weight of a 15 ft section of water-filled pipe plus 250 lbs. This is 1475 lbs. for 4" pipe.
3. Loads were determined by testing products in the orientation for which they were designed to be used. End-drilled parts were pulled in line with the anchor's axis while cross-drilled parts were tested with the force perpendicular to the axis.

### EZH515 & EZH516 HangerMate Anchors

#### Application Material:

Steel .187" – .500"

#### Specification:

1/4" shank diameter, one-piece anchor with cross-drilled head to accept 3/8-16 threaded rod and components, #5 self-drilling point and self-tapping threads

#### UL Listings and FM Approvals:

- EZH515: None
- EZH516 (with nuts) is UL listed and FM approved for 4" pipe in 16 gage steel (0.060")

#### Head Style:

9/16" diameter head cross-drilled and tapped to accept 3/8-16 threaded components

#### Head Height

3/4"

#### Drive Hex Size:

1/2" across flats

#### Shank Length:

1"

#### Shank Threads:

1/4-20 self-tapping

#### Point Type:

#5 self-drilling

#### Material & Heat Treat:

Carbon steel (AISI C10B21) case hardened and tempered

#### Finish:

Zinc plated per ASTM B633 Type II Class 12

#### Installation Tools:

- HangerMate drive socket: EZE215 with safety set feature; automatically disengages when anchor is seated
- Recommended power tool: Contractor-grade screw gun; 12 volt min. cordless or 4.5 amp min. corded tool 1300 – 2000 rpm

For more information, contact

**Elco Construction Products • 1.800.435.7213**  
**www.elcoconstruction.com**



## HangerMate® Threaded Rod Anchoring System EZH535 Anchors

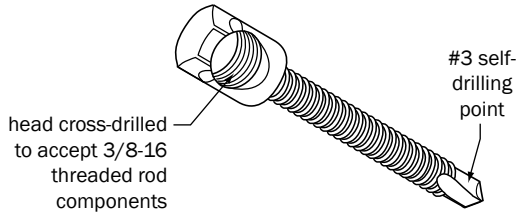

### Features & Benefits

- Cross-drilled and tapped for attaching 3/8-16 threaded components to steel
- Solid, one piece cold formed part; head cannot spin off or unscrew from body
- #3 self-drilling point for steel thicknesses of .060 - .250"

### Performance Values for EZG535 Anchor

Steel Thickness	Average Ultimate Value (lbs)
0.062"	2756
0.074"	2753
0.104"	2809
0.125"	2809
0.1875"	2809
0.250"	2809

1. The loads indicated above are average ultimate values achieved under laboratory conditions and appropriate safety factors should be applied for design purposes.
2. NFPA (National Fire Protection Assoc.) minimum fastening requirements are five times the weight of a 15 ft section of water-filled pipe plus 250 lbs. This is 1475 lbs. for 4" pipe.
3. Loads were determined by testing products in the orientation for which they were designed to be used. End-drilled parts were pulled in line with the anchor's axis while cross-drilled parts were tested with the force perpendicular to the axis.

### EZH535 HangerMate Anchors

#### Application Material:

Steel .060" - .250"

#### Specification:

1/4" shank diameter, one-piece anchor with end-drilled head to accept 3/8-16 threaded rod and components, #3 self-drilling point and self-tapping threads

#### UL Listings and FM Approvals:

None

#### Head Style:

9/16" diameter head cross-drilled and tapped to accept 3/8-16 threaded components

#### Head Height

3/4"

#### Drive Hex Size:

1/2" across flats

#### Shank Length:

2"

#### Shank Threads:

1/4-20 self-tapping

#### Point Type:

#3 self-drilling

#### Material & Heat Treat:

Carbon steel (AISI C10B21) case hardened and tempered

#### Finish:

Zinc plated per ASTM B633 Type II Class 5

#### Installation Tools:

- HangerMate drive socket: EZE215 with safety set feature; automatically disengages when anchor is seated
- Recommended power tool: Contractor-grade screw gun; 12 volt min. cordless or 4.5 amp min. corded tool 1300 - 2000 rpm

For more information, contact

**Elco Construction Products • 1.800.435.7213**

**www.elcoconstruction.com**



# S P E C I F I C A T I O N S

## HangerMate® Threaded Rod Anchoring System EZG315 Anchors

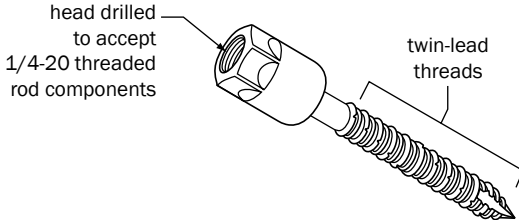

### Features & Benefits

- End-drilled and tapped for attaching 1/4-20 threaded components to wood
- Solid, one piece cold formed part; head cannot spin off or unscrew from body
- Type 17 point cuts threads into wood and wax coating reduces installation torque

### Performance Values for EZG315 Anchor

Average Ultimate Value (lbs)		
Douglas Fir	Southern Pine	Hem Fir
2487	2162	1768

### EZG315 HangerMate Anchors

#### Application Material:

Wood

#### Specification:

5/16" threaded shank diameter, one-piece anchor with high-low, waxed threads, Type 17 point and end-drilled head to accept 1/4-20 threaded rod components

#### UL Listings and FM Approvals:

None; 1/4-20 threaded rod not used for sprinkler applications

#### Head Style:

3/4" high, 9/16" diameter head end-drilled and tapped to accept 1/4-20 threaded components

#### Drive Hex Size:

1/2" across flats

#### Shank Length:

2-1/4"

#### Shank Threads:

5/16-14 high-low threads (waxed)

#### Point Type:

Type 17 (waxed) with shank slot

#### Material & Heat Treat

Carbon steel (AISI C10B21); no heat treat

#### Finish:

Zinc plated per ASTM B633 Type II Class 5

#### Installation Tools:

- HangerMate drive socket: EZE215 with safety set feature; automatically disengages when anchor is seated.
- Recommended power tool: Contractor-grade screw gun; 12 volt min. cordless or 6 amp. corded tool.
- In most applications, a pre-drilled hole is not needed. In exceptionally hard wood, drill hole only to minimum size required.

For more information, contact

**Elco Construction Products • 1.800.435.7213**

**www.elcoconstruction.com**

1. The loads indicated above are average ultimate values achieved under laboratory conditions and appropriate safety factors should be applied for design purposes.

2. NFPA (National Fire Protection Assoc.) minimum fastening requirements are five times the weight of a 15 ft section of water-filled pipe plus 250 lbs. This is 1475 lbs. for 4" pipe.

3. All test values were obtained using 3/8-16 rod. When 1/4-20 rod is used, the strength of the rod may be less than the pull-out values of the anchors.

4. Loads were determined by testing products in the orientation for which they were designed to be used. End-drilled parts were pulled in line with the anchor's axis while cross-drilled parts were tested with the force perpendicular to the axis.



# HangerMate® Threaded Rod Anchoring System

## EZG650 & EZG670 Anchors

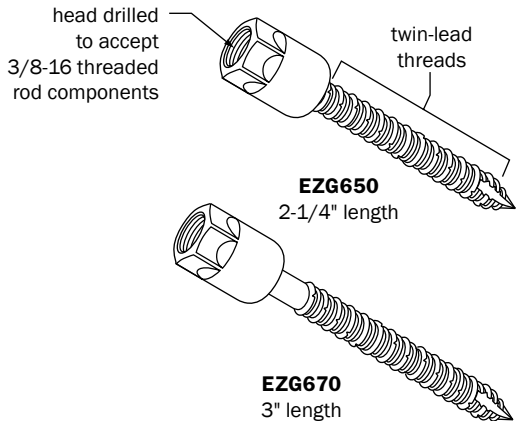

### Features & Benefits

- End-drilled and tapped for attaching 3/8-16 threaded components to wood
- Solid, one piece cold formed part; head cannot spin off or unscrew from body
- Type 17 point cuts threads into wood and wax coating reduces installation torque

### Performance Values for EZG650 & EZG670 Anchors

Average Ultimate Value (lbs)		
Douglas Fir	Southern Pine	Hem Fir
2487	2162	1768

1. The loads indicated above are average ultimate values achieved under laboratory conditions and appropriate safety factors should be applied for design purposes.
2. NFPA (National Fire Protection Assoc.) minimum fastening requirements are five times the weight of a 15 ft section of water-filled pipe plus 250 lbs. This is 1475 lbs. for 4" pipe.
3. Loads were determined by testing products in the orientation for which they were designed to be used. End-drilled parts were pulled in line with the anchor's axis while cross-drilled parts were tested with the force perpendicular to the axis.

# SPECIFICATIONS

## EZG650 & EZG670 HangerMate Anchors

### Application Material:

Wood

### Specification:

5/16" threaded shank diameter, one-piece anchor with high-low, waxed threads, Type 17 point and end-drilled head to accept 3/8-16 threaded rod components

### UL Listings and FM Approvals:

Both styles cULus Listed and FM approved for pipe up to 4"

### Head Style:

3/4" high, 9/16" diameter head end-drilled and tapped to accept 3/8-16 threaded components

### Drive Hex Size:

1/2" across flats

### Shank Length:

EZG650: 2-1/4"

EZG670: 3"

### Shank Threads:

5/16-14 high-low threads (waxed)

### Point Type:

Type 17 (waxed) with shank slot

### Material & Heat Treat

Carbon steel (AISI C10B21); no heat treat

### Finish:

Zinc plated per ASTM B633 Type II Class 12

### Installation Tools:

- HangerMate drive socket: EZE215 with safety set feature; automatically disengages when anchor is seated
- Recommended power tool: Contractor-grade screw gun; 12 volt min. cordless or 6 amp. corded tool
- In most applications, a pre-drilled hole is not needed. In exceptionally hard wood, drill hole only to minimum size required.

For more information, contact

**Elco Construction Products • 1.800.435.7213**

**www.elcoconstruction.com**





# S P E C I F I C A T I O N S

## HangerMate® Threaded Rod Anchoring System EZH320 Anchors

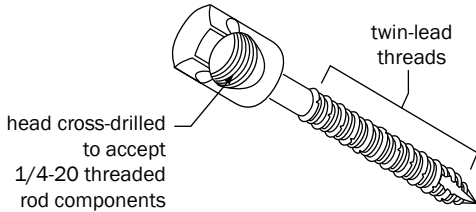

### Features & Benefits

- Cross-drilled and tapped for attaching 1/4-20 threaded components to wood
- Solid, one piece cold formed part; head cannot spin off or unscrew from body
- Type 17 point cuts threads into wood and wax coating reduces installation torque

### Performance Values for EZH320 Anchor

Average Ultimate Value (lbs)		
Douglas Fir	Southern Pine	Hem Fir
1801	1460	1451

### EZH320 HangerMate Anchors

#### Application Material:

Wood

#### Specification:

5/16" threaded shank diameter, one-piece anchor with high-low, waxed threads, Type 17 point and cross-drilled head to accept 1/4-20 threaded rod components

#### UL Listings and FM Approvals:

None; 1/4-20 threaded rod not used for sprinkler applications

#### Head Style:

3/4" high, 9/16" diameter head cross-drilled and tapped to accept 1/4-20 threaded components

#### Drive Hex Size:

1/2" across flats

#### Shank Length:

2-1/4"

#### Shank Threads:

5/16-14 high-low threads (waxed)

#### Point Type:

Type 17 (waxed) with shank slot

#### Material & Heat Treat

Carbon steel (AISI C10B21); no heat treat

#### Finish:

Zinc plated per ASTM B633 Type II Class 5

#### Installation Tools:

- HangerMate drive socket: EZE215 with safety set feature; automatically disengages when anchor is seated
- Recommended power tool: Contractor-grade screw gun; 12 volt min. cordless or 6 amp. corded tool
- In most applications, a pre-drilled hole is not needed. In exceptionally hard wood, drill hole only to minimum size required.

For more information, contact

**Elco Construction Products • 1.800.435.7213**

**www.elcoconstruction.com**

1. The loads indicated above are average ultimate values achieved under laboratory conditions and appropriate safety factors should be applied for design purposes.

2. NFPA (National Fire Protection Assoc.) minimum fastening requirements are five times the weight of a 15 ft section of water-filled pipe plus 250 lbs. This is 1475 lbs. for 4" pipe.

3. All test values were obtained using 3/8-16 rod. When 1/4-20 rod is used, the strength of the rod may be less than the pull-out values of the anchors.

4. Loads were determined by testing products in the orientation for which they were designed to be used. End-drilled parts were pulled in line with the anchor's axis while cross-drilled parts were tested with the force perpendicular to the axis.





# SPECIFICATIONS

## HangerMate® Threaded Rod Anchoring System EZH665 Anchors

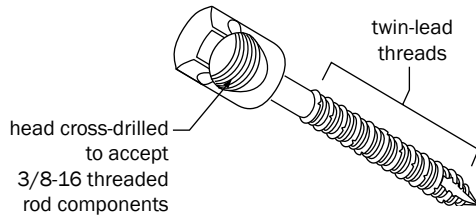

### Features & Benefits

- Cross-drilled and tapped for attaching 3/8-16 threaded components to wood
- Solid, one piece cold formed part; head cannot spin off or unscrew from body
- Type 17 point cuts threads into wood and wax coating reduces installation torque

### Performance Values for EZH665 Anchor

Average Ultimate Value (lbs)		
Douglas Fir	Southern Pine	Hem Fir
1801	1460	1451

1. The loads indicated above are average ultimate values achieved under laboratory conditions and appropriate safety factors should be applied for design purposes.
2. NFPA (National Fire Protection Assoc.) minimum fastening requirements are five times the weight of a 15 ft section of water-filled pipe plus 250 lbs. This is 1475 lbs. for 4" pipe.
3. Loads were determined by testing products in the orientation for which they were designed to be used. End-drilled parts were pulled in line with the anchor's axis while cross-drilled parts were tested with the force perpendicular to the axis.

### EZH665 HangerMate Anchors

#### Application Material:

Wood

#### Specification:

5/16" threaded shank diameter, one-piece anchor with high-low, waxed threads, Type 17 point and cross-drilled head to accept 3/8-16 threaded rod components

#### UL Listings and FM Approvals:

- cULus Listed for pipe up to 3-1/2" diameter

#### Head Style:

3/4" high, 9/16" diameter head cross-drilled and tapped to accept 3/8-16 threaded components

#### Drive Hex Size:

1/2" across flats

#### Shank Length:

2-1/4"

#### Shank Threads:

5/16-14 high-low threads (waxed)

#### Point Type:

Type 17 (waxed) with shank slot

#### Material & Heat Treat

Carbon steel (AISI C10B21); no heat treat

#### Finish:

Zinc plated per ASTM B633 Type II Class 12

#### Installation Tools:

- HangerMate drive socket: EZE215 with safety set feature; automatically disengages when anchor is seated
- Recommended power tool: Contractor-grade screw gun; 12 volt min. cordless or 6 amp. corded tool
- In most applications, a pre-drilled hole is not needed. In exceptionally hard wood, drill hole only to minimum size required.

For more information, contact

**Elco Construction Products • 1.800.435.7213**

**www.elcoconstruction.com**



# HangerMate® Threaded Rod Anchoring System

## EZG365 Anchors

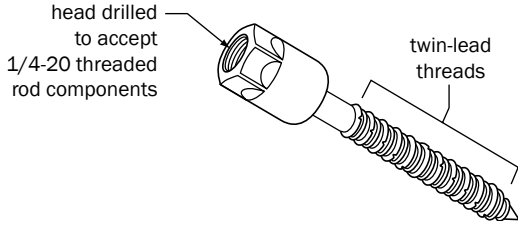

### Features & Benefits

- End-drilled and tapped for attaching 1/4-20 threaded components to concrete
- Solid, one piece cold formed part; head cannot spin off or unscrew from body
- Gimlet (tapered threads) point allows for easy starting in pre-drilled hole

### Performance Values for EZG365 Anchor

Average Ultimate Value (lbs)

3650 PSI Concrete

2188

1. The loads indicated above are average ultimate values achieved under laboratory conditions and appropriate safety factors should be applied for design purposes.
2. NFPA (National Fire Protection Assoc.) minimum fastening requirements are five times the weight of a 15 ft section of water-filled pipe plus 250 lbs. This is 1475 lbs. for 4" pipe.
3. All test values were obtained using 3/8-16 rod. When 1/4-20 rod is used, the strength of the rod may be less than the pull-out values of the anchors.
4. Loads were determined by testing products in the orientation for which they were designed to be used. End-drilled parts were pulled in line with the anchor's axis while cross-drilled parts were tested with the force perpendicular to the axis.

# S P E C I F I C A T I O N S

## EZG365 HangerMate Anchors

### Application Material:

Concrete

### Specification:

5/16" diameter, one-piece anchor with high-low thread, gimlet point and end-drilled head to accept 1/4-20 threaded rod components

### UL Listings and FM Approvals:

None; 1/4-20 threaded rod not used for sprinkler applications

### Head Style:

3/4" high, 9/16" diameter head end-drilled and tapped to accept 1/4-20 threaded components

### Drive Hex Size:

1/2" across flats

### Shank Length:

2-1/4"

### Shank Threads:

5/16-14 high-low threads

### Point Type:

Gimlet (threaded tapered)

### Material & Heat Treat:

Carbon steel (AISI C10B21) case hardened and tempered

### Finish:

Plating per ASTM B633 Type II Class 5

### Installation Tools:

A 1/4" ANSI bit must be used to drill proper hole. Any brand bit may be used, but use of the EZE340 bit (for hammer drills) and EZE240 bit holder, or the EZE350 SDS bit (for rotary hammer drills), will provide more efficient installation. Both bit types allow the use of the EZE220 drive sleeve, which can be easily slipped over the drill bit and used to seat the anchors.

If non-hex bit (e.g. standard bit) is used, the EZE215 socket can be used to seat anchors.

For more information, contact

**Elco Construction Products • 1.800.435.7213**

**www.elcoconstruction.com**



# HangerMate® Threaded Rod Anchoring System

## EZG730 Anchors

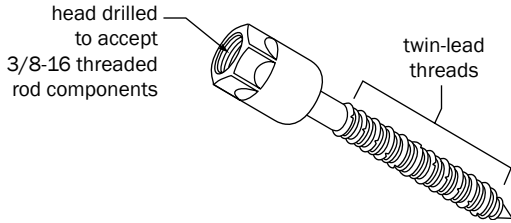

### Features & Benefits

- End-drilled and tapped for attaching 3/8-16 threaded components to concrete
- Solid, one piece cold formed part; head cannot spin off or unscrew from body
- Gimlet (tapered threads) point allows for easy starting in pre-drilled hole

#### Average Ultimate Value (lbs)

**3650 PSI Concrete**

2188

# SPECIFICATIONS

## EZG730 HangerMate Anchors

### Application Material:

Concrete

### Specification:

5/16" diameter, one-piece anchor with high-low thread, gimlet point and end-drilled head to accept 3/16-16 threaded rod components

### UL Listings and FM Approvals:

FM-approved for pipe up to 4" diameter

### Head Style:

3/4" high, 9/16" diameter head end-drilled and tapped to accept 3/8-16 threaded components

### Drive Hex Size:

1/2" across flats

### Shank Length:

2-1/4"

### Shank Threads:

5/16-14 high-low threads

### Point Type:

Gimlet (threaded tapered)

### Material & Heat Treat:

Carbon steel (AISI C10B21) case hardened and tempered

### Finish:

Plating per ASTM B633 Type II Class 5

### Installation Tools:

A 1/4" ANSI bit must be used to drill proper hole. Any brand bit may be used, but use of the EZE340 bit (for hammer drills) and EZE240 bit holder, or the EZE350 SDS bit (for rotary hammer drills), will provide more efficient installation. Both bit types allow the use of the EZE220 drive sleeve, which can be easily slipped over the drill bit and used to seat the anchors.

If non-hex bit (e.g. standard bit) is used, the EZE215 socket can be used to seat anchors.

1. The loads indicated above are average ultimate values achieved under laboratory conditions and appropriate safety factors should be applied for design purposes.

2. NFPA (National Fire Protection Assoc.) minimum fastening requirements are five times the weight of a 15 ft section of water-filled pipe plus 250 lbs. This is 1475 lbs. for 4" pipe.

3. Loads were determined by testing products in the orientation for which they were designed to be used. End-drilled parts were pulled in line with the anchor's axis while cross-drilled parts were tested with the force perpendicular to the axis.

For more information, contact

**Elco Construction Products • 1.800.435.7213**

**[www.elcoconstruction.com](http://www.elcoconstruction.com)**



# S P E C I F I C A T I O N S

## HangerMate® Threaded Rod Anchoring System EZH370 Anchors

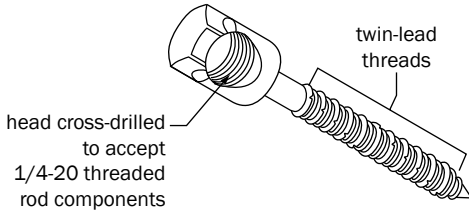

### Features & Benefits

- Cross-drilled and tapped for attaching 1/4-20 threaded components to concrete
- Solid, one piece cold formed part; head cannot spin off or unscrew from body
- Gimlet (tapered threads) point allows for easy starting in pre-drilled hole

#### Average Ultimate Value (lbs)

3650 PSI Concrete

2188

### EZH370 HangerMate Anchors

#### Application Material:

Concrete

#### Specification:

5/16" diameter, one-piece anchor with high-low thread, gimlet point and cross-drilled head to accept 1/4-20 threaded rod components

#### UL Listings and FM Approvals:

None; 1/4-20 threaded rod not used for sprinkler applications

#### Head Style:

3/4" high, 9/16" diameter head cross-drilled and tapped to accept 1/4-20 threaded components

#### Drive Hex Size:

1/2" across flats

#### Shank Length:

2-1/4"

#### Shank Threads:

5/16-14 high-low threads

#### Point Type:

Gimlet (threaded tapered)

#### Material & Heat Treat:

Carbon steel (AISI C10B21) case hardened and tempered

#### Finish:

Plating per ASTM B633 Type II Class 5

#### Installation Tools:

A 1/4" ANSI bit must be used to drill proper hole. Any brand bit may be used, but use of the EZE340 bit (for hammer drills) and EZE240 bit holder, or the EZE350 SDS bit (for rotary hammer drills), will provide more efficient installation. Both bit types allow the use of the EZE220 drive sleeve, which can be easily slipped over the drill bit and used to seat the anchors.

If non-hex bit (e.g. standard bit) is used, the EZE215 socket can be used to seat anchors.

For more information, contact

**Elco Construction Products • 1.800.435.7213**

**www.elcoconstruction.com**

1. The loads indicated above are average ultimate values achieved under laboratory conditions and appropriate safety factors should be applied for design purposes.
2. NFPA (National Fire Protection Assoc.) minimum fastening requirements are five times the weight of a 15 ft section of water-filled pipe plus 250 lbs. This is 1475 lbs. for 4" pipe.
3. All test values were obtained using 3/8-16 rod. When 1/4-20 rod is used, the strength of the rod may be less than the pull-out values of the anchors.
4. Loads were determined by testing products in the orientation for which they were designed to be used. End-drilled parts were pulled in line with the anchor's axis while cross-drilled parts were tested with the force perpendicular to the axis.



# HangerMate® Threaded Rod Anchoring System

## EZH735 Anchors

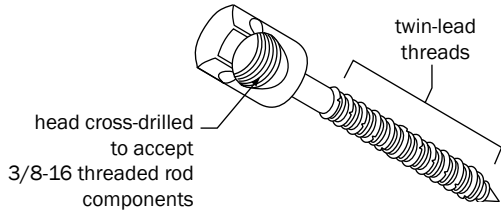

### Features & Benefits

- Cross-drilled and tapped for attaching 3/8-16 threaded components to concrete
- Solid, one piece cold formed part; head cannot spin off or unscrew from body
- Gimlet (tapered threaded) point allows for easy starting in pre-drilled hole

### Performance Values for EZH735 Anchor

Average Ultimate Value (lbs)  
**3650 PSI Concrete**  
 2188

1. The loads indicated above are average ultimate values achieved under laboratory conditions and appropriate safety factors should be applied for design purposes.
2. NFPA (National Fire Protection Assoc.) minimum fastening requirements are five times the weight of a 15 ft section of water-filled pipe plus 250 lbs. This is 1475 lbs. for 4" pipe.
3. Loads were determined by testing products in the orientation for which they were designed to be used. End-drilled parts were pulled in line with the anchor's axis while cross-drilled parts were tested with the force perpendicular to the axis.

# SPECIFICATIONS

## EZH735 HangerMate Anchors

### Application Material:

Concrete

### Specification:

5/16" diameter, one-piece anchor with high-low thread, gimlet point and cross-drilled head to accept 3/16-16 threaded rod components

### UL Listings and FM Approvals:

FM-approved for pipe up to 4" in diameter

### Head Style:

3/4" high, 9/16" diameter head cross-drilled and tapped to accept 3/16-16 threaded components

### Drive Hex Size:

1/2" across flats

### Shank Length:

2-1/4"

### Shank Threads:

5/16-14 high-low threads

### Point Type:

Gimlet (threaded tapered)

### Material & Heat Treat:

Carbon steel (AISI C10B21) case hardened and tempered

### Finish:

Plating per ASTM B633 Type II Class 5

### Installation Tools:

A 1/4" ANSI bit must be used to drill proper hole. Any brand bit may be used, but use of the EZE340 bit (for hammer drills) and EZE240 bit holder, or the EZE350 SDS bit (for rotary hammer drills), will provide more efficient installation. Both bit types allow the use of the EZE220 drive sleeve, which can be easily slipped over the drill bit and used to seat the anchors.

If non-hex bit (e.g. standard bit) is used, the EZE215 socket can be used to seat anchors.

For more information, contact

**Elco Construction Products • 1.800.435.7213**

**www.elcoconstruction.com**



# SPECIFICATIONS

## HangerMate® MP (Multi-Purpose) Threaded Rod Anchors EZG930, EZH935 & EZG910

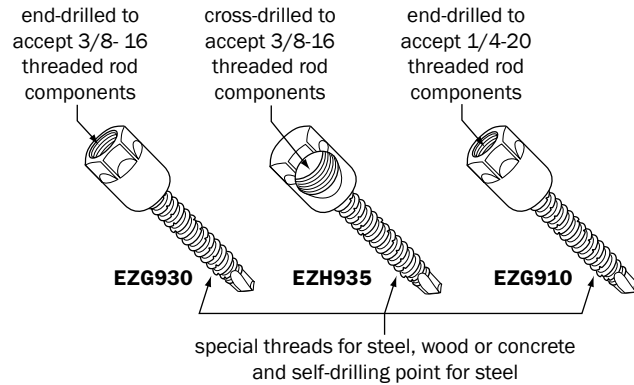

### Features & Benefits

- One anchor design for use in steel, wood or concrete; no need to carry separate parts for these different materials
- Two products end-drilled and tapped for attaching 1/4-20 (EZG910) or 3/8-16 (EZG930) threaded components to steel, wood or concrete
- One product (EZH935) cross-drilled to attach 3/8-16 threaded components to steel, wood or concrete
- Solid, one-piece cold formed part; head cannot spin off or unscrew from body
- Self-drilling point eliminates drilling operations in steel applications

### Performance Values – End-drilled Product Only

Average Ultimate Value (lbs)	
Application Material	Performance Values – End-drilled Products Only
Southern Pine	1541
16 ga. steel	880
14 ga. steel	1106
12 ga. steel	1754
1/8" steel	2505
Concrete (3300 psi)	2933

1. The loads indicated above are average ultimate values achieved under laboratory conditions and appropriate safety factors should be applied for design purposes.
2. NFPA (National Fire Protection Assoc.) minimum fastening requirements are five times the weight of a 15 ft section of water-filled pipe plus 250 lbs. This is 1475 lbs. for 4" pipe.
3. All test values were obtained using 3/8-16 rod. When 1/4-20 rod is used, the strength of the rod may be less than the pull-out values of the anchors.
4. Loads were determined by testing products in the orientation for which they were designed to be used.

### EZG930, EZH935 & EZG910 HangerMate Anchors

#### Application Material:

Steel, wood or concrete

#### Specification:

1/4" diameter, one-piece anchor with self-drilling point and end-drilled head to accept 3/8-16 threaded rod components

#### Head Style:

Drilled and tapped to accept 3/8-16 threaded components

#### Thread Size:

1/4-10

#### Length Under Head:

2"

#### Point Type:

Self-drilling

#### Material & Heat Treat:

Carbon steel (AISI C10B21) case hardened and tempered

#### Finish:

Plating per ASTM B633 Type II Class 12

#### Installation Tools:

##### In wood:

- HangerMate drive socket: EZE215 with safety set feature; automatically disengages when anchor is seated
- Recommended power tool: Contractor-grade screw gun; 12 volt min. cordless or 6 amp. corded tool
- In most applications, a pre-drilled hole is not needed. In exceptionally hard wood, drill hole only to minimum size required.

##### In concrete:

- A 7/32" ANSI bit must be used to drill proper hole. Any brand bit may be used, but use of the EZE340 bit (for hammer drills) and EZE240 bit holder, or the EZE350 SDS bit (for rotary hammer drills), will provide more efficient installation. Both bit types allow the use of the EZE220 drive sleeve, which can be easily slipped over the drill bit and used to seat the anchors.

##### In steel:

- HangerMate drive socket: EZE215 with safety set feature; automatically disengages when anchor is seated
- Recommended power tool: Contractor-grade screw gun; 12 volt min. cordless or 4.5 amp min. corded tool 1300 – 2000 rpm

For more information, contact

**Elco Construction Products • 1.800.435.7213**  
**www.elcoconstruction.com**



# S P E C I F I C A T I O N S

## HangerMate® Threaded Rod Adapter EZE270

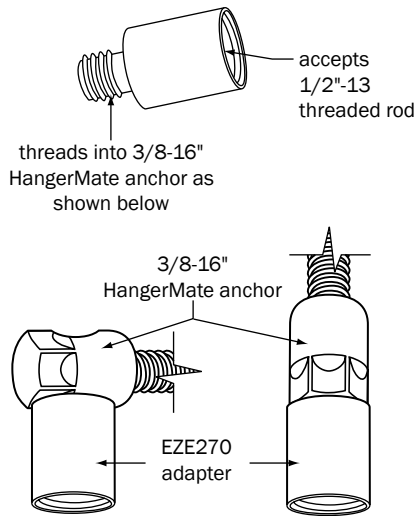

### Features & Benefits

- One-piece anchor threads into installed 3/8-16 HangerMate anchors
- Head end-drilled and tapped to accept 1/2-13 threaded rod components
- No special tools required; simply install any 3/8" HangerMate anchor as required, then thread EZE270 adapter into it by hand
- Use of adapter does not increase performance value of 3/8" HangerMate anchor – check corresponding 3/8" anchor spec sheet for load-carrying capacity and add appropriate safety factor

### EZE270 HangerMate Adapter

#### Application Material:

Fits appropriate 3/8-16 HangerMate anchor properly installed in steel, wood or concrete

#### Specification:

One-piece anchor with thread engineered for installation into 3/8-16 threaded rod anchors and head end-drilled to accept 1/2-13 threaded rod components

#### Head Style:

Drilled and tapped to accept 1/2-13 threaded components

#### Thread Size:

3/8-16

#### Material & Heat Treat:

Carbon steel (AISI C10B21) case hardened and tempered

#### Finish:

Plating per ASTM B633 Type II Class 12

#### Installation Tools:

Simply install any 3/8" HangerMate anchor as required, then thread EZE270 adapter into it.

Use of adapter does not increase performance value of 3/8" HangerMate anchor. Check corresponding 3/8" anchor spec sheet for load-carrying capacity and add appropriate safety factor.

For more information, contact

**Elco Construction Products • 1.800.435.7213**

**e-mail: [infoelco@acument.com](mailto:infoelco@acument.com)**

# HangerMate® Threaded Rod Anchoring System



## Installation Instructions



### HangerMate Installation Tools

Genuine HangerMate installation tool components, used with a contractor-grade screw gun, hammer drill or rotary hammer, install HangerMate anchors quickly, easily and with single-hand cycling for reduced installer fatigue. HangerMate installation tool components are designed specifically for installing HangerMate anchors and operate as an installation system to deliver consistent and optimal results.

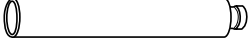
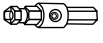
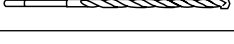
### Installation Tools Selection Guide

	Elco Catalog No.	Description
	EZE215	Drive Socket
	EZE220	Drive Sleeve
	EZE240	Drill Bit Adapter Kit
	EZE320	Collared 25/64 Drill Bit
	EZE340	ANSI 1/4" Tanged Drill Bit for Hammer Drills
	EZE350	ANSI 1/4" SDS Drill Bit for Rotary Hammer Drills
	EZE360	7/32" Tanged Drill Bit for Hammer Drills
	EZE380	7/32" SDS Drill Bit for Rotary Hammer Drills
	EZE290	Tool for EZG580/EZG590/EZG600/EZG610 components (HangerMate LG anchors)
	ELY100	Drill Bit Adapter for 7/32" drill bit



HangerMate drill bits are engineered for accurate drilling in concrete applications.



EZE220 drive sleeve slips over drill bits to ease installation of HangerMate anchors in concrete.



EZE290 tool speeds installation of HangerMate LG anchors.





# HangerMate® Threaded Rod Anchoring System Installation Instructions

## In Steel or Wood Applications\*

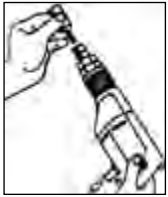

1. Insert HangerMate drive socket ZE215 into corded screw gun (min. 4.5 amps) or appropriate cordless screw gun.

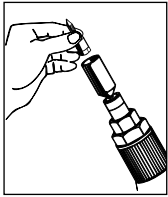

2. Insert appropriate HangerMate anchor into drive socket.



3. HangerMate anchors drill their own holes in metal and wood applications so predrilling is unnecessary. Simply position the self-drilling point of the anchor at the intended point of installation and with the screw gun operating at approximately 1800 rpm, install the HangerMate anchor. The drive socket's SafetySet feature will set the anchor flush and then automatically disengage to prevent over-driving.

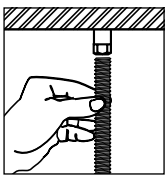

4. The HangerMate anchor is now installed and ready to accept a threaded rod or component.

### NOTE:

- As with all cutting tools and fasteners, normal safety precautions should be observed to avoid electrical installations, other utilities and reinforcement bars; careful use will provide the utmost safety and reliability.
- The wearing of safety glasses by users and persons in the vicinity is required by Federal Law.
- Shoulders of installed HangerMate anchors must be flush to the metal, masonry or wood substrate materials. HangerMate anchors should not be subjected to vibratory or shock loads resulting from such applications as anchorings for reciprocating machinery, crane rails or hoists.
- Care should be taken to not damage HangerMate anchors or the substrate into which they are installed when loading pipe, installing cable tray, or otherwise suspending components from HangerMate anchors. Failure to do so may result in significant loss of holding power.
- Complete HangerMate product information and technical application assistance is available from Elco Construction Products by calling 800-435-7213.

## For Light-Gage Steel Applications

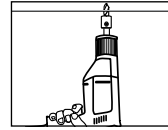

1. Drill a 25/64" hole in the steel using the EZE320 drill bit with stopping collar. Collar is designed to limit penetration, to reduce the risk of damaging the roof membrane in decking applications. Standard 25/64" bits can be used but care should be taken if a roof membrane could potentially be damaged.

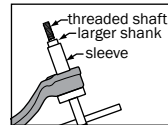

2. Using the EZE290 tool: Rotate tool shaft until threaded shaft is fully out of sleeve and unthreaded, larger shaft is slightly protruding from sleeve.

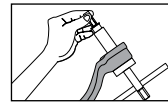

3. Thread collapsing insert onto threaded shaft until it hits larger shaft.

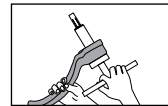

4. Rotate shaft clockwise until head of collapsing insert hits tool sleeve.

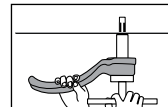

5. Insert collapsing insert fully into drilled 25/64" hole.

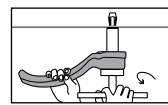

6. Turn shaft clockwise until firm resistance is felt. This should take 3 to 4 complete revolutions. Do not over-tighten or twist tool off-axis or threaded tip could break off.

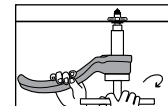

7. Turn shaft counterclockwise to break threads of tool loose from insert. Remove tool by continuing counterclockwise rotation of shaft. It will take 7 to 8 revolutions to remove the tool. (NOTE: If insert spins while backing out, it is not fully installed. Re-apply clockwise motion with added force to fully collapse insert.)

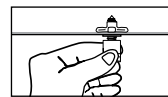

8. If installing 3/8"-16 threaded rod or other components\*, screw in 3/8"-16 hanger until finger-tight. If desired, a 1/2" hex drive socket in a power tool can be used to more quickly install hanger. BE CAREFUL NOT TO CROSS-THREAD.

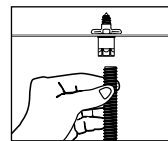

9. Thread 3/8"-16 rod\* or other component into hanger.

\*NOTE: If installing 1/4"-20 threaded rod or similar components, simply thread it directly into the collapsed insert. No other hanger is needed.

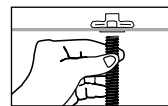

**NOTE:** Instructions for installing into concrete applications are on the following page.



## Elco Construction Products

1301 Kerr Drive • Decorah, IA 52101

**1.800.435.7213** • fax: 563.387.3540

[www.elcoconstruction.com](http://www.elcoconstruction.com)

# HangerMate® Threaded Rod Anchoring System Installation Instructions



## For Concrete Applications

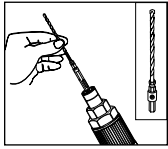

1. Insert appropriate HangerMate carbide-tipped drill bit into hammer or rotary hammer drill. For SDS-drive drills, use Elco drill bit ZE350; for keyed chuck-type drills, use Elco tanged bit ZE340 installed in adapter ZE240 (inset).



2. With the drill in the hammer mode, drill at least 2-1/2" into the concrete.

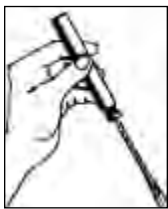

3. Slide ZE220 drive sleeve over drill bit, locking its internal hex recess with the hex collar of the drill bit.



4. Insert appropriate HangerMate anchor into the drive sleeve. Disengage hammer mode and engage drill-only mode.

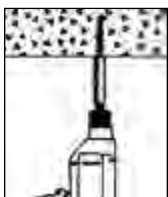

5. Place tip of the HangerMate anchor into drilled hole and drive until the SafetySet feature seats the anchor and disengages.

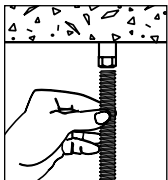

6. The installed HangerMate anchor is now ready to accept a threaded rod or component. Successive installations are even easier. Simply remove the drive sleeve from the drill bit, drill hole(s) and repeat steps 3 through 5.

## NOTE:

- As with all cutting tools and fasteners, normal safety precautions should be observed to avoid electrical installations, other utilities and reinforcement bars; careful use will provide the utmost safety and reliability.
- The wearing of safety glasses by users and persons in the vicinity is required by Federal Law.
- Shoulders of installed HangerMate anchors must be flush to the metal, masonry or wood substrate materials. HangerMate anchors should not be subjected to vibratory or shock loads resulting from such applications as anchorings for reciprocating machinery, crane rails or hoists.
- Care should be taken to not damage HangerMate anchors or the substrate into which they are installed when loading pipe, installing cable tray, or otherwise suspending components from HangerMate anchors. Failure to do so may result in significant loss of holding power.
- Complete HangerMate product information and technical application assistance is available from Elco Construction Products by calling 800-435-7213.

## WARRANTY:

This literature was prepared as a summary of the HangerMate threaded rod anchoring system from Elco Construction Products and is not, therefore, intended to describe all hazards, limitations, warnings, precautions, etc. pertaining to the use of the product. The information and data presented herein are believed to be accurate and reliable, however, due to the wide variety of possible intervening factors, the suitability of the product for the use intended is the sole responsibility of the user. Specifications and other information contained herein supersede all previously published material and are subject to change without notice.

All HangerMate anchors are warranted to be manufactured free from defects in material and workmanship. Under this warranty, Elco Construction Products will provide, at no charge, replacement product for any HangerMate anchors proven to be defective when installed in accordance with our published recommendations and in applications considered by us as suitable for this product. This warranty is in lieu of any and all warranties, expressed or implied, and in no case will Elco Construction Products be liable for incidental, liquidated or consequential damages.



## Elco Construction Products

1301 Kerr Drive • Decorah, IA 52101

**1.800.435.7213**

fax: 563.387.3540

**www.elcoconstruction.com**



**WARRANTY:**

This literature was prepared as a summary of the HangerMate® threaded rod anchoring system from Elco Construction Products and is not, therefore, intended to describe all hazards, limitations, warnings, precautions, etc. pertaining to the use of the product. The information and data presented herein are believed to be accurate and reliable, however, due to the wide variety of possible intervening factors, the suitability of the product for the use intended is the sole responsibility of the user. Specifications and other information contained herein supersede all previously published material and are subject to change without notice.

All HangerMate anchors are warranted to be manufactured free from defects in material and workmanship. Under this warranty, Elco Construction Products will provide, at no charge, replacement product for any HangerMate anchors proven to be defective when installed in accordance with our published recommendations and in applications considered by us as suitable for this product. This warranty is in lieu of any and all warranties, expressed or implied, and in no case will Elco Construction Products be liable for incidental, liquidated or consequential damages.

For more information on how the HangerMate threaded rod anchoring system can benefit your application, please contact:



**Elco Construction Products**

1301 Kerr Drive • Decorah, IA 52101

**1.800.435.7213**

fax: 563.387.3540

**www.elcoconstruction.com**

**Distributed By:**

